

SPiiPlusCMxa

Installation Guide

February 2022

Document Revision: 3.11.03

SPiiPlusCMxa

Release Date: February 2022

COPYRIGHT

© ACS Motion Control Ltd., 2022. All rights reserved.

Changes are periodically made to the information in this document. Changes are published as release notes and later incorporated into revisions of this document.

No part of this document may be reproduced in any form without prior written permission from ACS Motion Control.

TRADEMARKS

Windows and Intellisense are trademarks of Microsoft Corporation.

EtherCAT® is registered trademark and patented technology, licensed by Beckhoff Automation GmbH, Germany.

Any other companies and product names mentioned herein may be the trademarks of their respective owners.

PATENTS

Israel Patent No. 235022

US Patent Application No. 14/532,023

Europe Patent application No.15187586.1

Japan Patent Application No.: 2015-193179

Chinese Patent Application No.: 201510639732.X

Taiwan(R.O.C.) Patent Application No. 104132118

Korean Patent Application No. 10-2015-0137612

www.acsmotioncontrol.com

support@acsmotioncontrol.com

sales@acsmotioncontrol.com

NOTICE

The information in this document is deemed to be correct at the time of publishing. ACS Motion Control reserves the right to change specifications without notice. ACS Motion Control is not responsible for incidental, consequential, or special damages of any kind in connection with using this document.





Date	Revision	Description
February 2022	3.11.03	Connection Diagram for MARK input, diagram labels
January 2022	10.00.03	Voltage Auto-detect note correction
December 2021	1.00.02	Diagram corrections
December 2021	1.00.01	Corrections after review
November 2021	1.00	First release

Conventions Used in this Guide

Text Formats

Format	Description
Bold	Names of GUI objects or commands
BOLD + UPPERCASE	ACSPL+ variables and commands
<code>Monospace + grey background</code>	Code example
<i>Italic</i>	Names of other documents
Blue	Hyperlink
[]	In commands indicates optional item(s)
	In commands indicates either/or items

Flagged Text

	Note - includes additional information or programming tips.
	Caution - describes a condition that may result in damage to equipment.
	Warning - describes a condition that may result in serious bodily injury or death.
	Model - highlights a specification, procedure, condition, or statement that depends on the product model
	Advanced - indicates a topic for advanced users.

Related Documentation

Documents listed in the following table provide additional information related to this document.

Authorized users can download the latest versions of the documents from [ACS Downloads](#).

Document	Description
SPiiPlus ACSPL+ Programmer's Guide	Provides practical instruction on how to use ACSPL+ to program your motion controller.
SPiiPlus Command & Variable Reference Guide	Describes all of the variables and commands available in the ACSPL+ programming language.
SPiiPlus MMI Application Studio User Guide	Explains how to use the SPiiPlus MMI Application Studio and associated monitoring tools.
SPiiPlus Setup Guide	Provides guidance on how to configure and adjust the SPiiPlus systems to work with supported types of motors and feedback devices.
<i>SPiiPlus Utilities User Guide</i>	A guide for using the SPiiPlus User Mode Driver (UMD) for setting up communication with the SPiiPlus motion controller.
<i>PEG and MARK Operations Application Notes</i>	Provides details on using the PEG commands in SPiiPlus systems.
<i>Using Absolute Encoders with ACS Products Application Note</i>	Addresses the physical connections, configuration and operation of absolute encoders with ACS networking products.

Table of Contents

1. Introduction	12
1.1 Document Scope	12
1.2 Product Overview	12
2. Detailed Description	13
2.1 SPiiPlusCMxa Package Content	13
2.2 Connectors	13
2.3 Jumpers	14
2.4 LED Indicators	14
2.4.1 System Control LEDs	14
2.4.2 Communication LEDs	15
2.4.3 Safety LEDs	15
2.5 Optional Accessories	16
2.5.1 Mating Connector Kit	16
2.5.2 STO Breakout Cable	17
2.6 Ordering Options	19
3. Operation	21
3.1 Cabling Recommendations	21
3.2 Standalone Control Module Operation	21
3.3 Motor Connection	21
3.4 Electro-Magnetic Immunity and Interference Considerations	24
3.5 Regeneration	24
3.6 Mechanical Motor Braking	25
4. Feedback	27
4.1 Encoder Types and Assignment	27
4.2 Encoder Power Supply	27
4.3 Incremental Digital AqB Encoder	27
4.4 Sin-Cos Encoders	28
4.5 Absolute Encoder Support	29
4.6 Pulse Direction Interface	31
4.7 Position Event Generation (PEG)	33
5. Power Supplies	35
5.1 Control Supply	35

5.2 Mechanical Brake	35
5.3 Digital Input/ Output Supply	35
5.4 Safety Inputs Supply	35
5.5 Drive Power Supply	35
5.6 Integrated Digital Drives	35
6. Digital Inputs and Outputs	37
6.1 Digital Outputs	37
6.2 Digital Inputs	38
6.3 Hall Sensors	38
6.4 Registration MARK Inputs	38
7. Analog Inputs and Outputs	40
7.1 General Purpose Analog Inputs	40
7.2 General Purpose Analog Outputs	40
8. Other Inputs	42
8.1 Right and Left Limit Inputs	42
8.2 Emergency Stop	43
8.3 STO Input Connections	44
8.4 Motor Over Temperature Fault	44
8.5 SPiiPlusCMxa Jumpers	45
8.6 Jumper Configuration for Sink and Source	46
8.7 SPiiPlusCMxa DIP Switches	46
9. Fault Indications	48
10. Grounding and Shielding	51
11. Personal Safety Guidelines	52
12. Dimensions and Installation	53
13. SPiiPlusCMxa Specifications	55
13.1 Control Supply Input Power	55
13.2 Brake Supply Input	55
13.3 Drive Power Supply	56
13.4 Power Bridge (Per Axis)	59
13.5 AqB Digital Encoder	61
13.6 SIN-COS Analog Encoder (Optional)	62
13.7 Absolute Encoder (Optional)	63
13.8 STO Inputs	64

13.9	HALL Inputs	64
13.10	Mechanical Brake High Power	64
13.11	Mechanical Brake Logic Signal	65
13.12	Limit Inputs	65
13.13	E-Stop Inputs	66
13.14	Digital Inputs	66
13.15	Digital Outputs	66
13.16	MARK Inputs	67
13.17	PEG Pulse	67
13.18	PEG STATE Pulse	67
13.19	General Purpose Analog Inputs	68
13.20	General Purpose Analog Outputs	68
13.21	Motor Over Temperature	68
13.22	External P/D Drive Support (Option)	69
13.23	Ethernet Port	70
13.24	EtherCAT Ports	70
13.25	Environment	71
13.26	Applicable Standards	71
14.	SPiiPlusCMxa Connectors	72
14.1	J6 – Ethernet Connector	72
14.2	J1,J2 – EtherCAT Connectors	73
14.3	J8 – Safety Connector	73
14.4	J9 – Digital & Analog I/O Connector	74
14.5	J10 – Stepper Drive Control Connector	76
14.6	J11, J13 & J15 – HALL & Encoder Connectors	79
14.7	J12, J14 & J16 – SIN-COS Encoder Connector	81
14.8	J17 – Control & Brake Supply Connector	82
14.9	J18 – Drive Supply Connector	83
14.10	J19 – Regeneration Connector	84
14.11	J20, J21 & J22 Motor Outputs Connector	84
14.12	J26 – PEG Connector	85
14.13	J29 Encoder Connector	87
14.14	STO Connector	88

List Of Figures

Figure 1-1. SPiiPlusCMxa	12
Figure 2-1. Control supply mating connector	13
Figure 2-2. Drive supply mating connector	13
Figure 2-3. Regeneration mating connector	13
Figure 2-4. Connectors on Front and Side Panels	14
Figure 2-5. SPiiPlusCMxa LED Indicators	14
Figure 2-6. STO-ACC1 Breakout Cable	17
Figure 3-1. 3-Phase Motor Connection	22
Figure 3-2. DC Brush Motor Connection	23
Figure 3-3. 2-Phase Step Motor Connection	23
Figure 3-4. Internal Regeneration Connection	24
Figure 3-5. External Regeneration Connection	25
Figure 3-6. Mechanical Motor Brake	25
Figure 4-1. Incremental Digital AqB Encoder Connections	28
Figure 4-2. Sin-Cos Encoder Connections	29
Figure 4-3. Absolute Encoder Connection With Clock	30
Figure 4-4. Absolute Encoders Without Clock	31
Figure 4-5. Pulse and Direction electrical schematic	31
Figure 4-6. Drive Enable of P/D module (axis 5)	32
Figure 4-7. Fault signal electrical schematic, 'source' and 'sink' connectivity scheme.	33
Figure 6-1. Digital Output Connection (source)	37
Figure 6-2. Digital Output Connection (sink)	37
Figure 6-3. Source Digital Inputs	38
Figure 6-4. Sink Digital Inputs	38
Figure 6-5. Differential Connection for MARK1 Input	39
Figure 7-1. General Purpose Analog Inputs	40
Figure 7-2. Analog output schematic diagram	41
Figure 8-1. Right Limit (Source) schematic diagram	42
Figure 8-2. Right Limit (Sink) schematic diagram	43
Figure 8-3. Emergency Stop Source Input	43
Figure 8-4. Emergency Stop (Sink) schematic diagram	44
Figure 8-5. STO Inputs	44

Figure 8-6. Motor Over Temperature Connection	45
Figure 8-7. Jumper Locations	45
Figure 8-8. Sink or Source Jumper Configuration	46
Figure 8-9. SPiiPlusCMxa line DIP Switches	46
Figure 10-1. Grounding and Shielding	51
Figure 12-1. SPiiPlusCMxa Front	53
Figure 12-2. SPiiPlusCMxa Side	53
Figure 12-3. SPiiPlusCMxa Bottom	54
Figure 12-4. SPiiPlusCMxa Rear	54
Figure 14-1. RJ45 Ethernet Mating Connector	72
Figure 14-2. EtherCAT RJ45 Mating Connector	73
Figure 14-3. Mating Connector for J8	73
Figure 14-4. J9 Mating Connector	74
Figure 14-5. J10 Mating Connector	76
Figure 14-6. Hall and Encoder Mating Connector	79
Figure 14-7. SIN-COS Encoder Mating Connector	81
Figure 14-8. J17 Mating Connector	82
Figure 14-9. J18 Mating Connector	83
Figure 14-10. Regeneration mating connector	84
Figure 14-11. J26 Mating Connector	85
Figure 14-12. STO Connector	88

List of Tables

Table 2-1. SPiiPlusCMxa System Control LEDs	15
Table 2-2. SPiiPlusCMxa Communication LEDs	15
Table 2-3. SPiiPlusCMxa Safety LEDs	16
Table 2-4. STO Cable Pinout	18
Table 8-1. SPiiPlusCM Jumpers	46
Table 9-1. Table 6: Faults and Warning Messages	48
Table 14-1. J1 Connector Pinout	72
Table 14-2. J1 Connector Pinout	73
Table 14-3. J8 Connector Pinout	74
Table 14-4. J9 Connector Pinout	75
Table 14-5. J10 Connector Pinout	77
Table 14-6. J11, J13 & J15 Connectors Pinout	80
Table 14-7. J12, J14 & J16 Pinout	81
Table 14-8. J17 Connectors Pinout	82
Table 14-9. J18 Connector Pinout	83
Table 14-10. Connector Pinout	84
Table 14-11. J20, J21 & J22 Connector Pinout	85
Table 14-12. Connector Pinout	85
Table 14-13. J29 Connector Pinout	87
Table 14-14. STO Connector Pinout	88

1. Introduction

1.1 Document Scope

This document describes the hardware details for the SPiiPlusCMxa, including electrical interfacing, device compatibility, mounting, and ventilation.

1.2 Product Overview

The SPiiPlusCMxa (shown in [Figure 1-1](#)) is a state-of-the-art line of EtherCAT network master multi-axis machine and motion controllers with up to three digital drives. As an EtherCAT master, it controls ACS' line of EtherCAT servo and step motor drives and I/Os modules, as well as any (ACS certified) EtherCAT module that complies with the CAN over EtherCAT (CoE) protocol.

See *ACS Qualified 3rd Party Products List* for details on products qualified to work with ACS products.

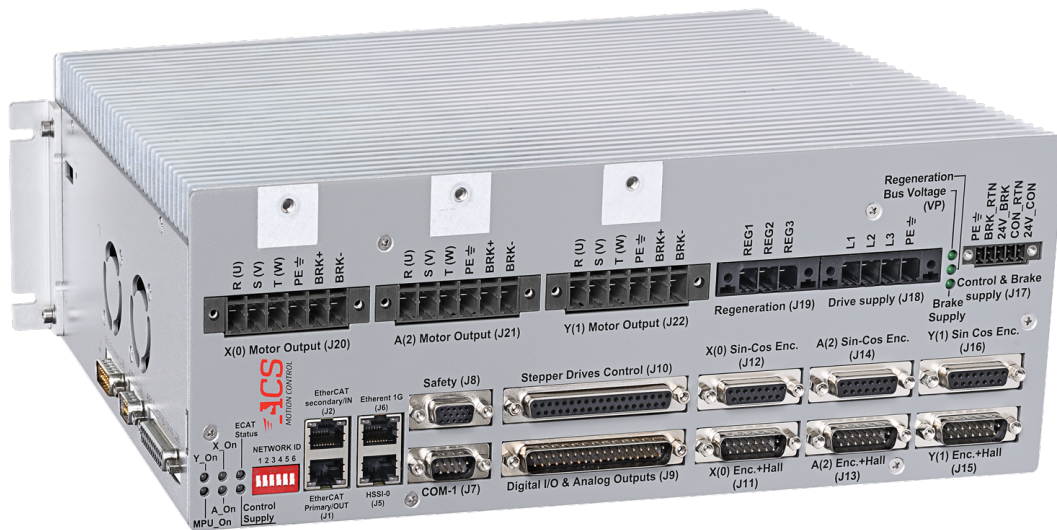

Figure 1-1. SPiiPlusCMxa

The product may be powered by a single or three phase 100-240 ($\pm 10\%$) VAC supply or by a 120 to 375 VDC supply. A separate 24 VDC control supply keeps all low voltage signals alive during emergency conditions.

2. Detailed Description

2.1 SPIIPlusCMxa Package Content

The SPIIPlusCMxa package contains:

- > SPIIPlusCMxa Module
- > Control supply mating connector for J17 (1743171 (MC 1,5/ 5-STF-3,81 BK) PHOENIX CONTACT)



Figure 2-1. Control supply mating connector

- > Drive supply mating connector for J18 (1930070000 (BVZ 7.62HP/04/180F SN BK) WEIDMULLER)



Figure 2-2. Drive supply mating connector

- > Mating connector for J19, Regeneration connector, P/N Weidmuller 1930060000.



Figure 2-3. Regeneration mating connector

Actual connector has 3 pins, image is for reference

2.2 Connectors

Connectors are on the front and side panels.

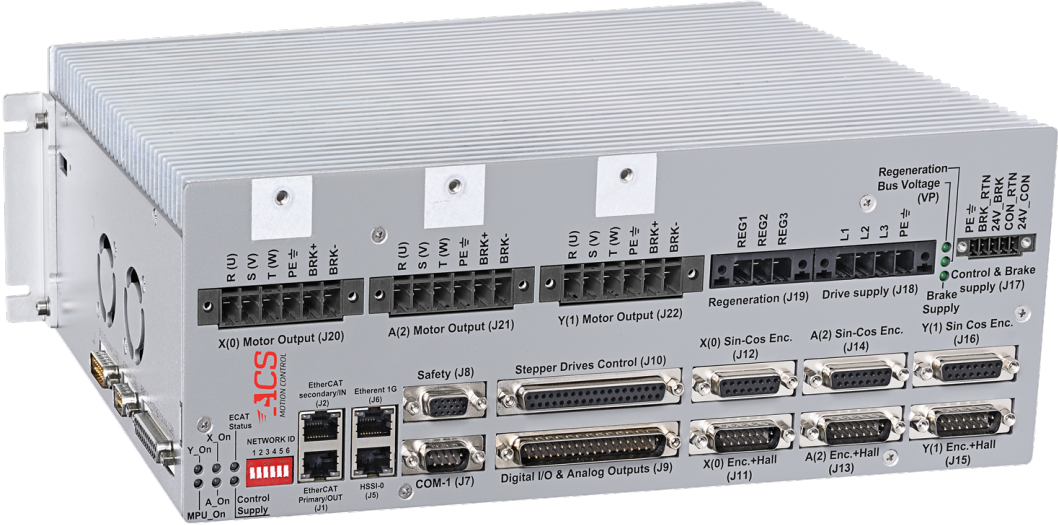

Figure 2-4. Connectors on Front and Side Panels

For details about connectors see [SPiiPlusCMxa Connectors](#)

2.3 Jumpers

For details about the connectors, see [SPiiPlusCMxa Jumpers](#).

2.4 LED Indicators

The SPiiPlusCMxa line has three sets of LED indicators as shown in [Figure 2-5](#).

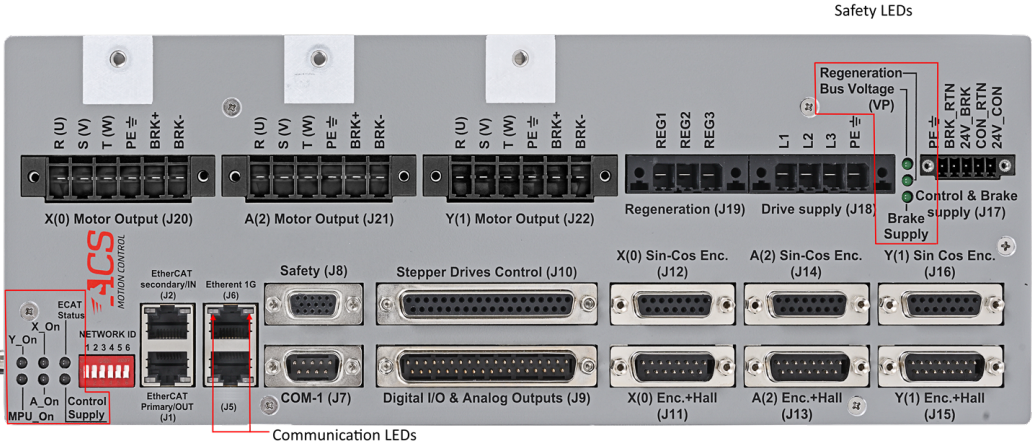

Figure 2-5. SPiiPlusCMxa LED Indicators

2.4.1 System Control LEDs

Table 2-1 summarizes the meaning of the SPiiPlusCMxa line System Control LED indicators.

Table 2-1. SPiiPlusCMxa System Control LEDs

Indication	Description
Control Supply	Green, when on – power is applied
MPU_On	Bicolor. > Red – Communication Fault > Green – Communication ok > Blinking – SW command
\$_On	Bicolor, one per axis (X, Y and A), indicates axis' status. > Off – Disabled > Green – Enabled > Red – Fault

2.4.2 Communication LEDs

The Communication LEDs are located on the RJ45 connectors, [Table 2-2](#) summarizes the meaning of the SPiiPlusCMxa line Communication LED indicators.

Table 2-2. SPiiPlusCMxa Communication LEDs

Indication	Description
Link/Activity	Green > Off – No link > On – Link exists, no data transferred > Blinking – Data being transferred
Run	Yellow. > Off – The unit is in the INIT state > Blinking (slow) – The unit is in the PRE-OPERATIONAL state > Single Flash – The unit is in the SAFE-OPERATIONAL state > On – The unit is in the OPERATIONAL state > Flickering (fast) – The unit is in the BOOTSTRAP state

2.4.3 Safety LEDs

[Table 2-3](#) summarizes the meaning of the SPiiPlusCMxa line Safety LED indicators.

Table 2-3. SPiiPlusCMxa Safety LEDs

Indication	Description
Bus Voltage	<p>Green</p> <ul style="list-style-type: none"> > On – bus voltage exists > Off – no bus voltage exists
Regeneration	<p>Green</p> <ul style="list-style-type: none"> > On – Regeneration circuit is ok > Off – Regeneration circuit failed > Blinking – regeneration is active
Brake Supply	<p>Green</p> <ul style="list-style-type: none"> > On – brake supply exists > Off – no brake supply exists

2.5 Optional Accessories

2.5.1 Mating Connector Kit

P/N: CMUDMxa-ACC1

Connector	Part Description	Manufacturer	Manufacturer P/N	Quantity
J17, J21, J22 Connector	PCB Connector	PHOENIX CONTACT	CONNECTOR PHOENIX PC4/6-STF-7,62 BLACK	3
J12, J14, J16 Connector	Connector	Amphenol	AMPHENOL 17SDA15P;2row 15pin male NPB	3
J26 PEG Connector	Supply	Amphenol	G17S-2510-110-EU	1
J10-Stepper Drives Control	Stepper Drives Control	Amphenol	G17S-3710-110EU	1
J8 Safety Connector	Safety Connector	Chant Sincere	101AE-15MGPA3	1

Connector	Part Description	Manufacturer	Manufacturer P/N	Quantity
J7, J28 - COM1/2	RS232 Connector	Amphenol	G17S-0900-110-EU	2
J12, J14, J16 Connectors	Encoder Connectors	Amphenol	G17S-1500-110EU	4
J9 Digital and Analog I/O	I/O Connector	Amphenol	L17SD C 37 S / G17S-3700-110	1
Hood for 9-pin connectors	HOOD HD-09-7; 9position RoHS	CHANT SINCERE CO., LTD Keltron	216AE09P0AB004 5507-09G-107-F8	3
Hood for 15-pin connectors	HOOD KELTRON HD-15-10; 15positio NPB	CHANT SINCERE CO., LTD	216AE-15P0AB004	6
Hood for 25-pin connectors	HOOD HD-25-10.5; 25posit	CHANT SINCERE CO., LTD Keltron	216AE25P0AB004 5507-25G-107-F8	1

2.5.2 STO Breakout Cable

P/N: STO-ACC1

Description: 2 meter cable with the STO mating connector on one end and flying leads on the other.



Figure 2-6. STO-ACC1 Breakout Cable

Table 2-4. STO Cable Pinout

	Name	Description
1	STO1-	STO input 1 inverted input
2	STO1+	STO input 1 non inverted input
3	NC	not connected
4	STO2+	STO input 2 non inverted input
5	STO2-	STO input 2 inverted input

2.6 Ordering Options

Ordering Options	Field	Example User Selection	Values
Built-In Drive Axes	1	1	1,2,3
Current Rating	2	A	A- 5/10A B- 10/20A C- 15/30A
500 kHz SinCos Encoder Channels	3	0	0,1,2,3
Absolute Encoder Channels	4	0	0, 1, 2, 3
Functional Safety	5	N	N=None, T=STO & SS1
16-bit SinCos and Analog Inputs	6	N	N = No (12-bit), Y = Yes
Max. Number of Controller Axes	7	4	4, 8, A = 16, B = 32, C = 64
Max MPU Cycle Rate (kHz) & MotionBoost	8	D	D = Default (2kHz for 32 axes or less, 1kHz for 64 axes), 2, 4, 5
Number of ACSPL+ Buffers & Real-Time C Function Support	9	D	D = Default A = 16 B = 32 C = 64 E = Default & Real-Time C Function Support Enabled F = 16 & Real-Time C Function Support Enabled G = 32 & Real-Time C Function Support Enabled H = 64 & Real-Time C Function Support Enabled
ServoBoost Number of Axes Supported	10	N	N=None, A=4, B=8, C=12, D=16...P=60, Q=64 (Use of ServoBoost on internal CMxa drives requires 16-bit SinCos and Analog Inputs = Y)
G-Code	11	N	N=None G=G-Code
Input Shaping	12	N	N=No S=Input Shaping
PDMnt Installed	13	N	N = No P = PDMnt installed (requires Max Number of Controller Axes = 8 or higher)
LearningBoost	14	N	N = No L=LearningBoost
NetworkBoost or Flexible Configuration	15	N	N = No B = NetworkBoost F = Flexible Configuration C = NetworkBoost & Flexible Configuration

Ordering Options	Field	Example User Selection	Values
Number of XL Scan scanners supported	16	0	0, 1, 2...9
Non-Linear Control	17	N	N = No C=Non-Linear Control (not supported on internal drives of the CMxa)
Reserved for Future Use	18	N	N

Example: CMxa1A00NN4DDNNNNNN0NN Description: 1 axis 5/10A

Field	1	2	3	4	5	6	7	8	9	10	11	12	13	14	15	16	17	18
PN CMxa	1	A	0	0	N	N	4	D	D	N	N	N	N	N	N	0	N	N

3. Operation

The SPiiPlusCMxa is a line of triple/dual/single axis EtherCAT controllers. For out of box operation follow the steps detailed below, referring to the detailed information provided in this manual and to the referred ACS documents.



The product's operation depends on ordered features.

3.1 Cabling Recommendations

For drive cables type selection follow the recommendations of motor supplier. As a general rule for all cables used, it is recommended using shielded (meshwork of tinned copper wire with high optical covering), high voltage withstand and very low capacitance cables. ACS specifies and tests this product using motor cable lengths of 10m. Motor cables should be routed as far as possible from sensitive-signal carrying cables such as encoder cables. Encoder cables should be selected according to the manufacturer's recommendations. The drive cables' shield should be connected to specified pin of the motor connector (refer to connector pin-outs in the sections that follow).

3.2 Standalone Control Module Operation

Product set up consists of the following stages:



Please read the safety instructions in [Personal Safety Guidelines](#) and closely adhere to them.

1. Connect the supply and control cables using pre-wired cables, according to the recommended connectors and pin-out detailed in [SPiiPlusCMxa Connectors](#).
2. Apply control and drive supply voltages and observe LEDs.
3. From your host computer, running SPiiPlus MMI Application Studio and SPiiPlus User Mode Driver, Establish communication with SPiiPlusCMxa using either the Ethernet connection via the J6 connector, or serial connection via J7 or J28. Refer to the *SPiiPlus Setup Guide* for details.
4. To set up the product: refer to the *SPiiPlus Setup Guide*.
5. For operation and programming: refer to the *ACSPL+ Programmer's Guide*.

3.3 Motor Connection

The built-in universal drives support 2- and 3-phase permanent magnet synchronous (DC brushless/AC servo), DC brush, voice coil, 2- and 3-phase stepper (micro-stepping open or closed loop) and AC induction* motors. Selection of motor and parameter setting is done using the Adjuster Wizard of the SPiiPlus MMI Application Studio (refer to *SPiiPlus MMI Application Studio User Guide*).



* Consult ACS.

A 3-phase motor connection is depicted in [Figure 3-1](#). An optional motor filter is shown in series between the drive and the motor. A shielded cable should be used, terminated in the EGND pin which is internally connected to the chassis (PE). If needed, the shield/GND may be connected to the motor's chassis to provide a seamless common ground reference.

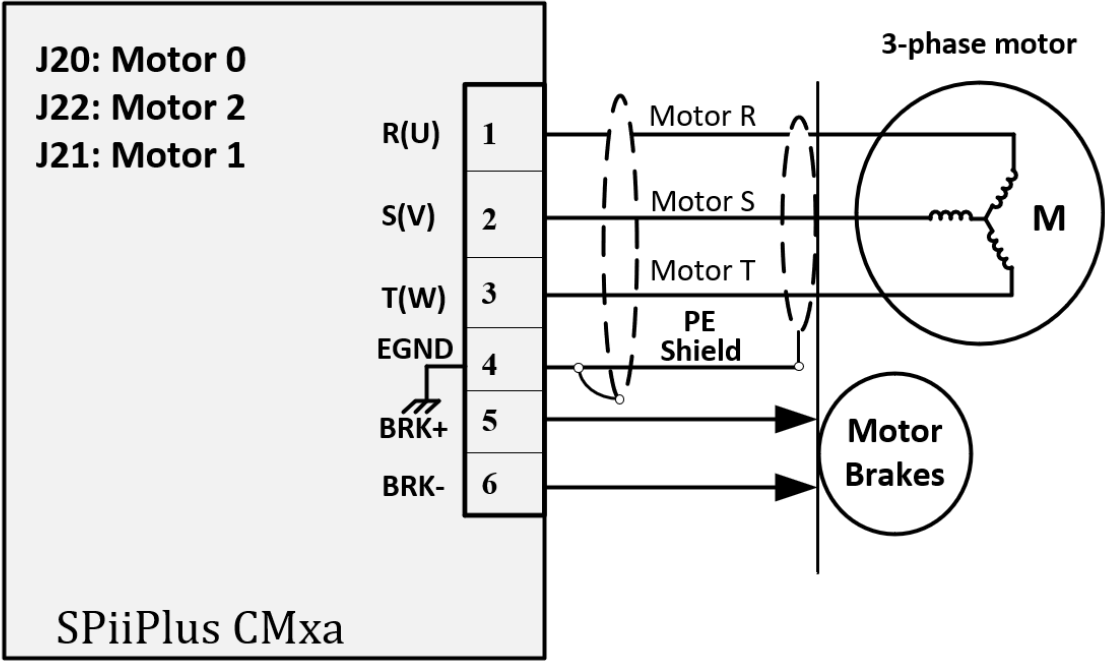

Figure 3-1. 3-Phase Motor Connection

For DC brush motor connections do not connect phase T (refer to [Figure 3-2](#)).

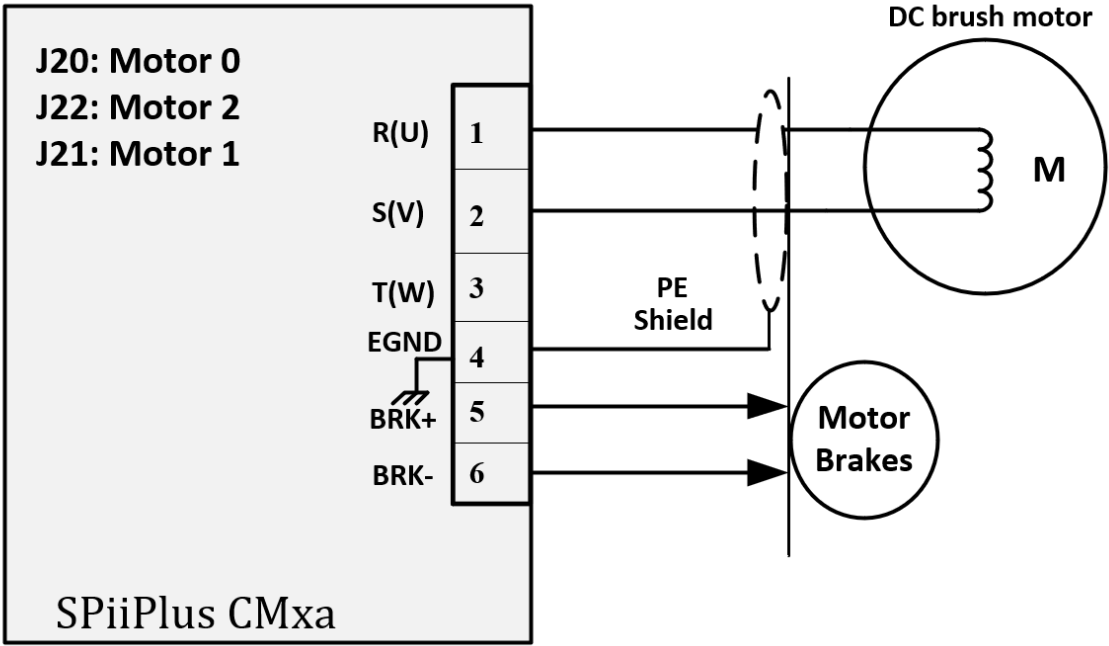

Figure 3-2. DC Brush Motor Connection

For 2-phase step motors connect the motor phases between S-R and between T-R as shown in Figure 3-3.

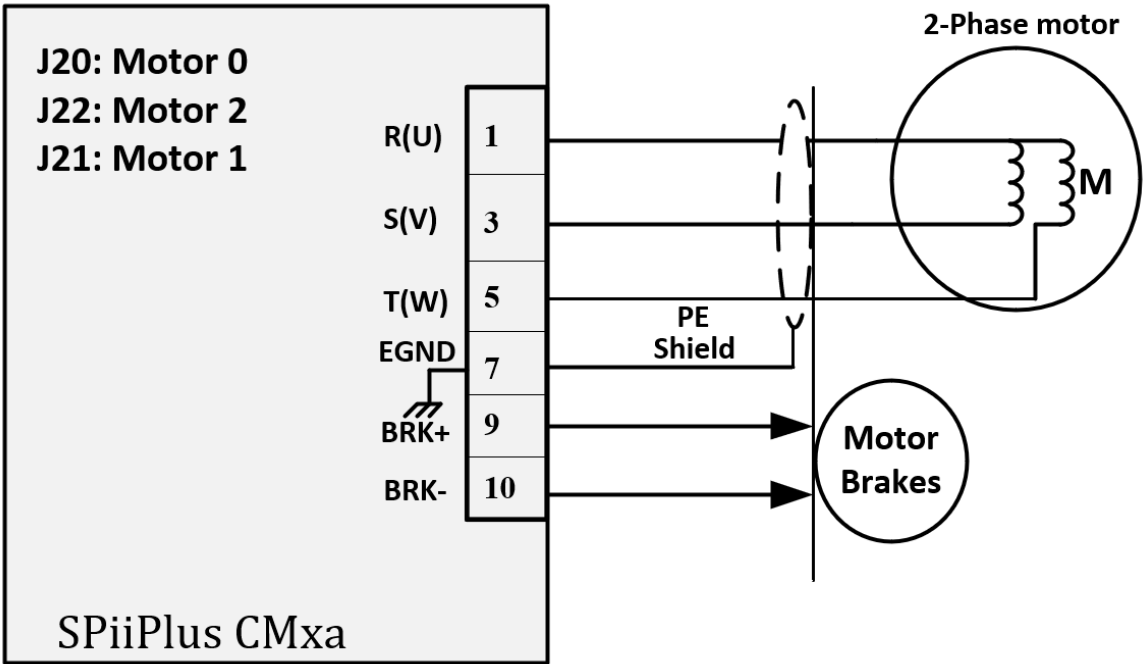

Figure 3-3. 2-Phase Step Motor Connection

3.4 Electro-Magnetic Immunity and Interference Considerations

Due consideration should be given to the following recommendations in order to minimize electromagnetic interference to power supply and neighboring equipment, and in order to improve electromagnetic immunity.

- > AC line filter (EPCOS B84142-B25-R equivalent), for AC supply interference protection.
- > Motor filters between the drive and the motor. The filters should be connected as close as possible to the drive's output connectors. Note that the filters require air flow cooling.
- > For motor cables use shielded (meshwork of tinned, copper wire with high optical covering), high voltage withstand and very low capacitance cables. ACS specifies and tests its products using motor cable lengths of up to 10m lengths. Motor cables should be routed as far as possible from sensitive-signal carrying cables such as encoder cables. Encoder cables should be according to manufacturer's recommendation. The motor cables' shield should be connected to motor connector pin 4.
- > Lightning protection on the supply AC lines should be provided in the cabinet/machine where the ACS product is being used. It is recommended to install power surge lightning arrestors (varistors) between the AC terminals (L-N, L-PE, N-PE). ACS recommends using the MNF Wurth Electronic, MNF P/N 820422711 varistor.

3.5 Regeneration

In order to absorb excess mechanical reverse energy translated into electrical energy during deceleration, and to avoid a voltage rise beyond the drive's overvoltage protection level, an internal 100R/100Watt resistor is provided. In order to apply this resistor, the user should short pins 1 and 3 in connector J19 as depicted in [Figure 3-4](#)

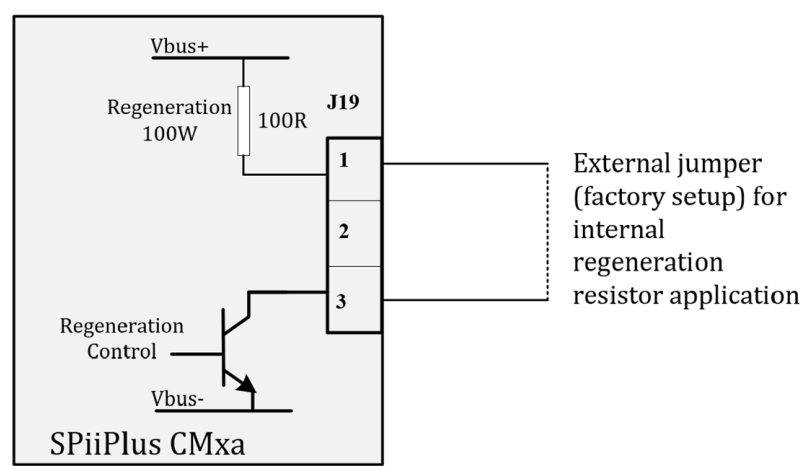

Figure 3-4. Internal Regeneration Connection

For demanding motion profiles an external shunt can be connected to pins 2 and 3 of J19 (as depicted in Figure 3-5), thus bypassing the internal regeneration resistor. External shunt minimum resistance is 13Ω.

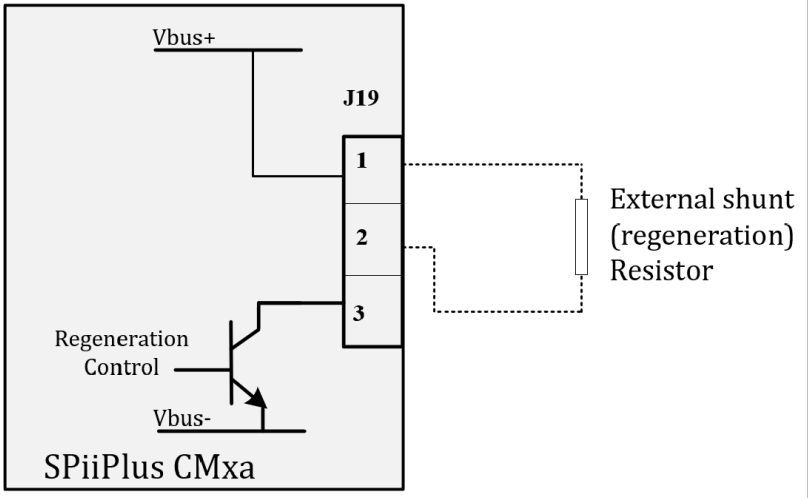

Figure 3-5. External Regeneration Connection

3.6 Mechanical Motor Braking

Three 24V/1A mechanical brake opto-isolated control outputs are available, one output per axis. These outputs are powered by dedicated external 24V logic supply. The outputs are protected against shorts.

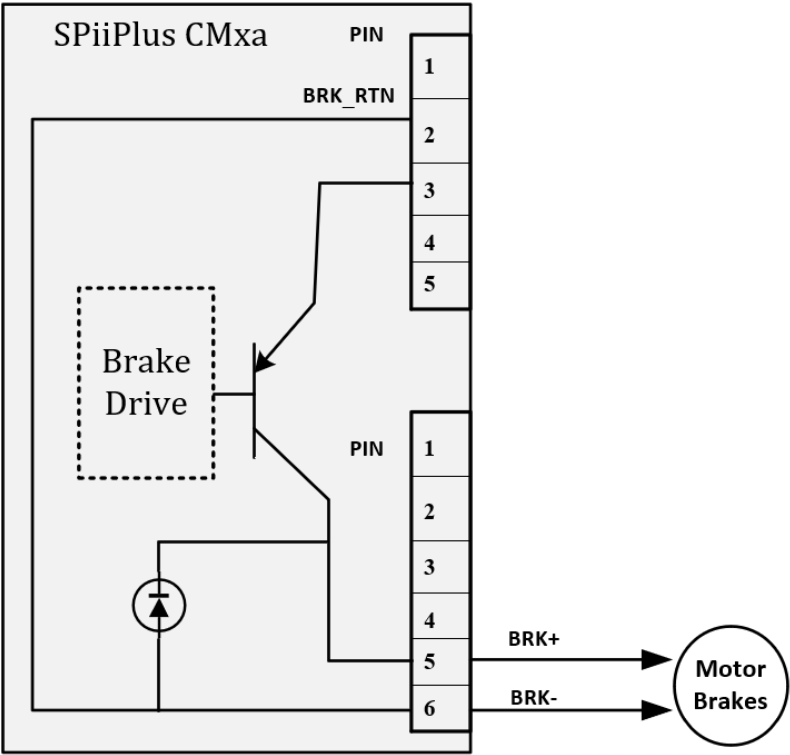

Figure 3-6. Mechanical Motor Brake

The mechanical brake outputs can be optionally used as General Purpose outputs from connector (J9).

4. Feedback

4.1 Encoder Types and Assignment

The SPiiPlusCMxa line supports multiple feedback types per each axis: Incremental digital encoders (up to a total of 4) which can be assigned to any axis. Sin-Cos analog (ordering option, 1 per axis), Hall sensors (3 sets per axis) and absolute encoders (ordering option, up to 3 total). The type of encoder and the number of encoders has to be specified when ordering, and cannot be modified at field level.

Dual feedback (dual loop) topology per axis is supported. Note that in a multi-axis network configuration, the number of utilized network axes is identical to the number of digital encoders used. For example, when a dual feedback scheme is implemented for 2 axes, 4 network axes are consumed out of the total number of network axes supported and ordered for the specific SPiiPlusCMxa.

4.2 Encoder Power Supply

The unit includes a built-in $5V \pm 5\%$ 1A(total) encoder supply.

4.3 Incremental Digital AqB Encoder

Each internal drive supports one or two incremental digital AqB encoders. The number of supported incremental encoders is by a factory setup and cannot be changed in the field.

The interface of each of the encoder's A, B and Index signal is depicted in Figure 4-1.

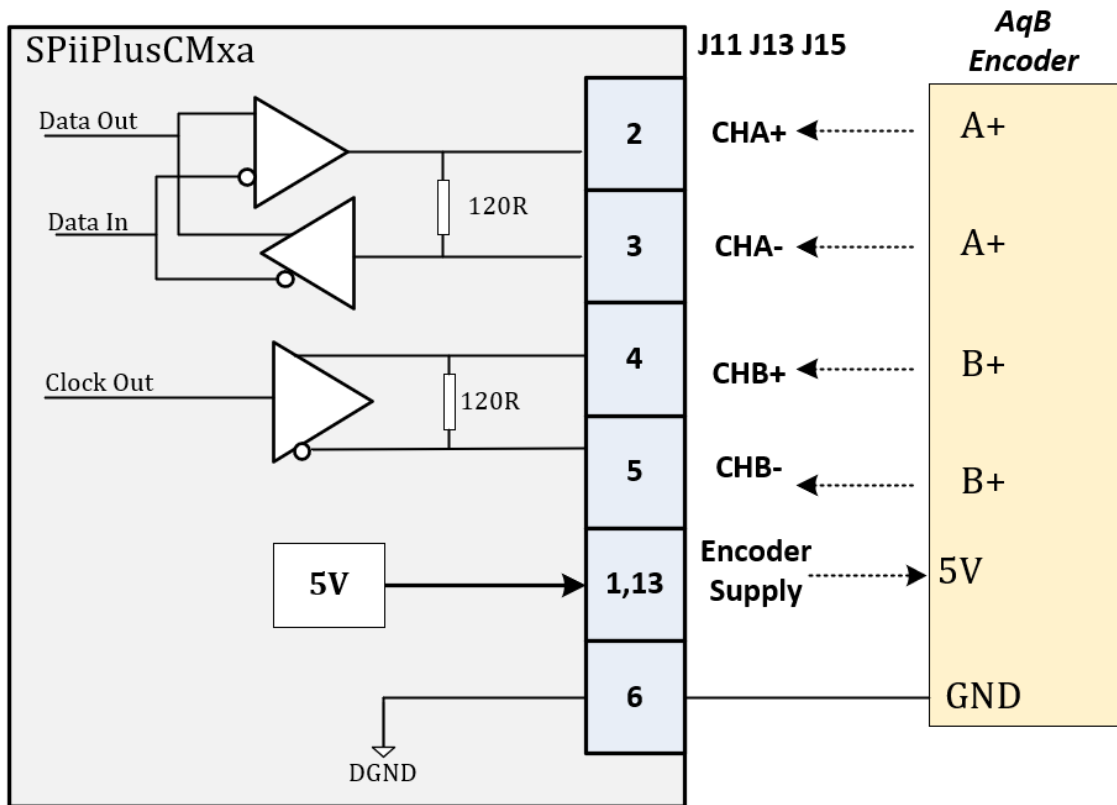

Figure 4-1. Incremental Digital AqB Encoder Connections

The interface is a protected RS-422 differential line with 120Ω termination.

- > Maximum rate: 12.5MHz which equals 40 million quadrature counts/sec
- > Fault detection: 'Encoder error' (due to noise), and 'Encoder not connected' are detected.
- > The encoders power supply is referenced to a digital ground.
- > A, B, I and Clk/Dir modes of operation are supported.

4.4 Sin-Cos Encoders

Optionally, the product supports one Sin-Cos encoder per axis. This number of supported Sin-Cos encoders is set at the factory according to ordered license. The interface for the Sine, Cosine and Index signals (Figure 4-2) is differential, 1V_{pt} ±10%. The maximal input frequency is 50 million encoder counts per second.

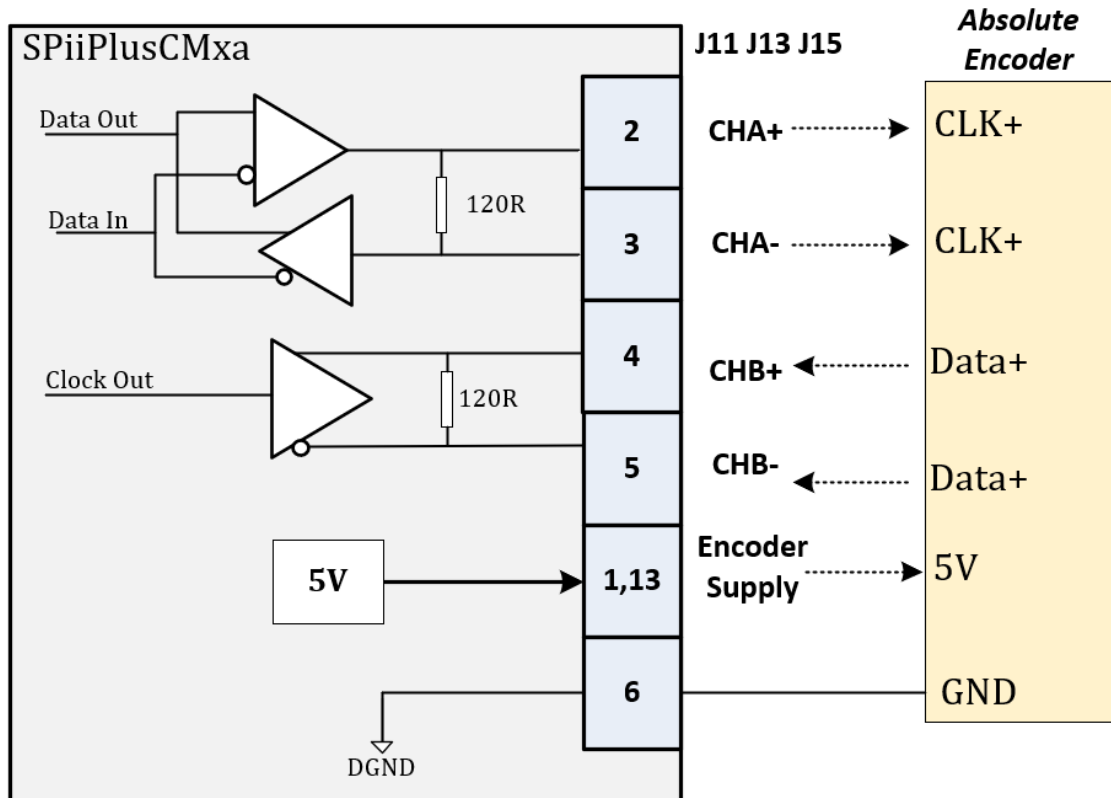

Figure 4-2. Sin-Cos Encoder Connections

Sin and Cos inputs are sampled in 20kHz at 12-bit or 16-bit resolution, according to the configuration ordered. A multiplication factor of 4 up to 4,096 for 12-bit resolution or 65536 for 16-bit resolution is supported. A software based Offset, Gain and Phase compensations can be set using the SPiiPlus MMI Application Studio Sin Cos Encoder Compensation tool which optimizes and sets the compensation values, stores the optimized values and displays the results graphically. 'Encoder error' and 'Encoder Not Connected' are reported as faults.

A license is an ACS permit to use or activate certain features within the product. A license is ordered as part of the product's purchasing configuration (prior to delivery), or after the product has been delivered and a need exists to expand the product's capabilities. When ordered as part of the product, the customer does not need to perform anything in order to activate the ordered features. When ordered after the product has been delivered, the customer has to download and activate the ACS-sent (by email) string to the controller, using the MMI.

4.5 Absolute Encoder Support

The SPiiPlusCMxa supports the following absolute encoders: Endat 2.2, SmartABS, BiSS and Panasonic.



The user should check with ACS regarding the particular required encoder type since many different versions exist per encoder standard.

The absolute encoders' electrical interfaces and connector pins are shared with AqB digital encoder's functional pins: AqB encoder A± interface is used for bidirectional DATA transfer, and AqB encoder B± interface is used for clock transmission to applicable encoders. Refer to [J11, J13 & J15 – HALL & Encoder Connectors](#) for pin numbers.

Cable lengths: absolute encoders have been tested with cables length of up to 30 m with encoder supplier's provided cables. For encoder connection use a shielded twisted pair cable such as BELDEN 9506, or its equivalent.

The physical interface is automatically reconfigured following the encoder type selection. The encoder type must be pre-ordered as defined in the SPiiPlusCMxa part number.

An attempt to select an encoder type that does not match the actual ordered encoder results in an error.

[Figure 4-3](#) depicts the physical connection of the SPiiPlusCMxa line and absolute encoders using a clock. This connection is appropriate for EnDAT2.2 and BiSS-C encoders.

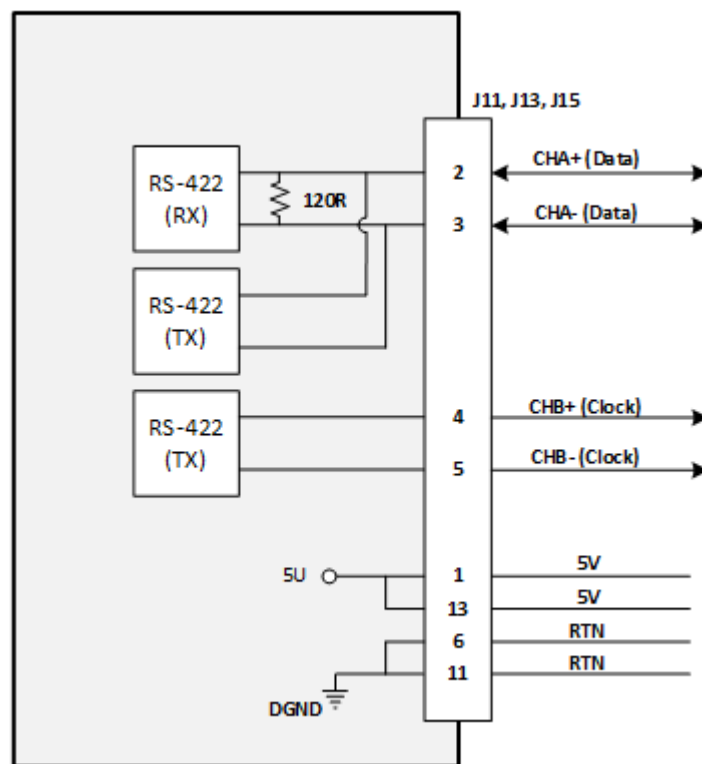

Figure 4-3. Absolute Encoder Connection With Clock

[Figure 4-3](#) depicts the physical connection of the SPiiPlusCMxa line and absolute encoders without a clock. This connection is appropriate for Panasonic and SmartABS encoders.

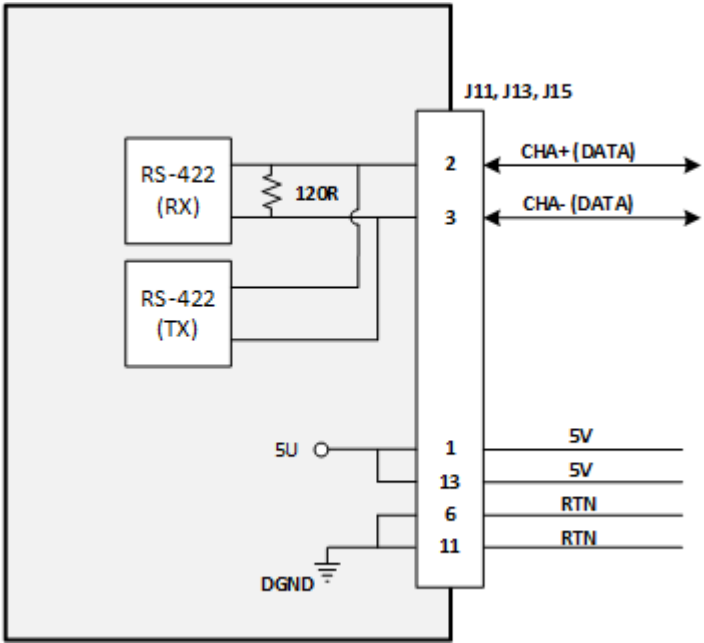

Figure 4-4. Absolute Encoders Without Clock

4.6 Pulse Direction Interface

The PD optional module consists of 4 Pulse Direction interfaces, each consisting of a Pulse output, Direction output, Enable output, and Fault input signals. The PD module occupies 4 network axes, numbered 5,6,7 and 8. Refer to the schematics below for Pulse and Direction interfaces, Enable signal interface, and 'source' and 'sink' configurations for the Fault signal.

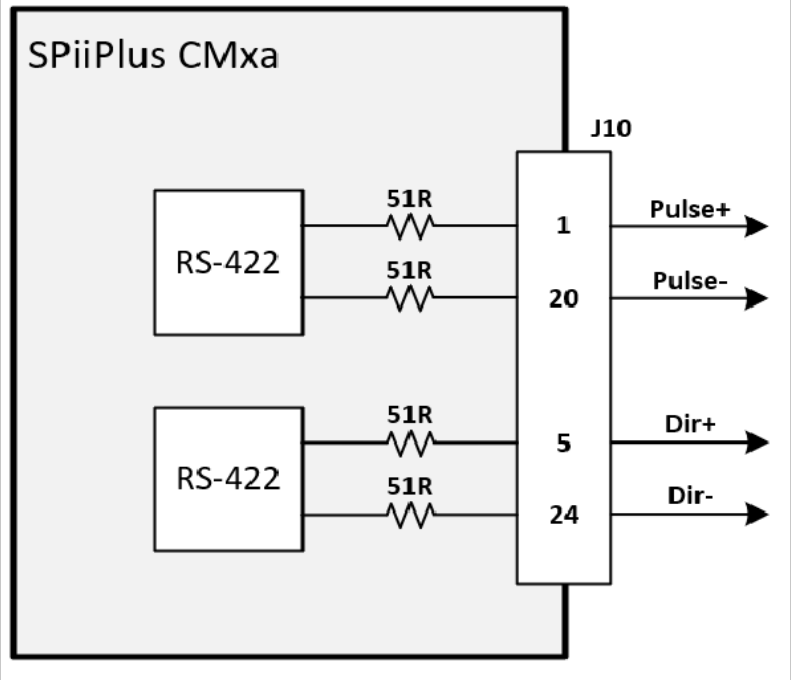

Figure 4-5. Pulse and Direction electrical schematic

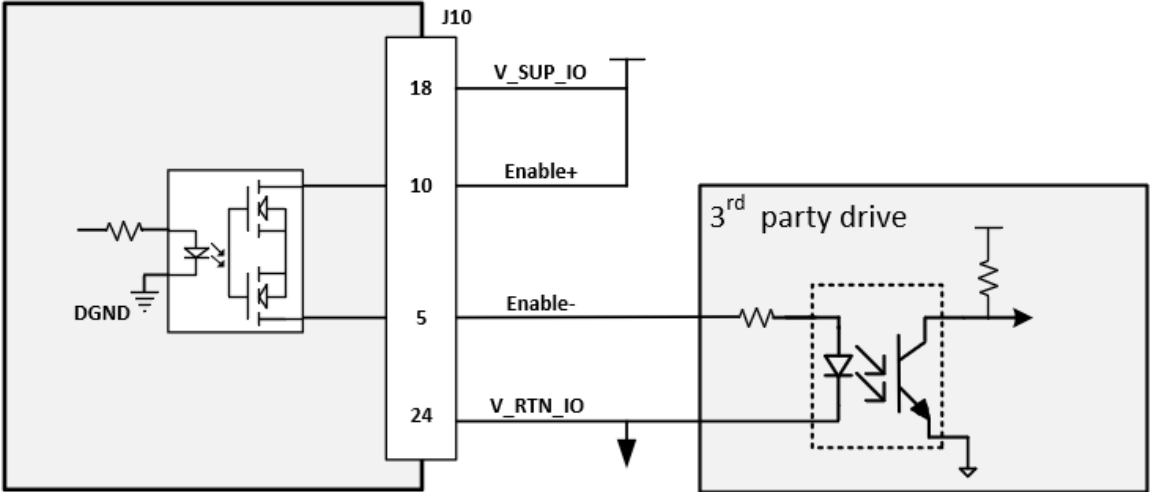

Figure 4-6. Drive Enable of P/D module (axis 5)

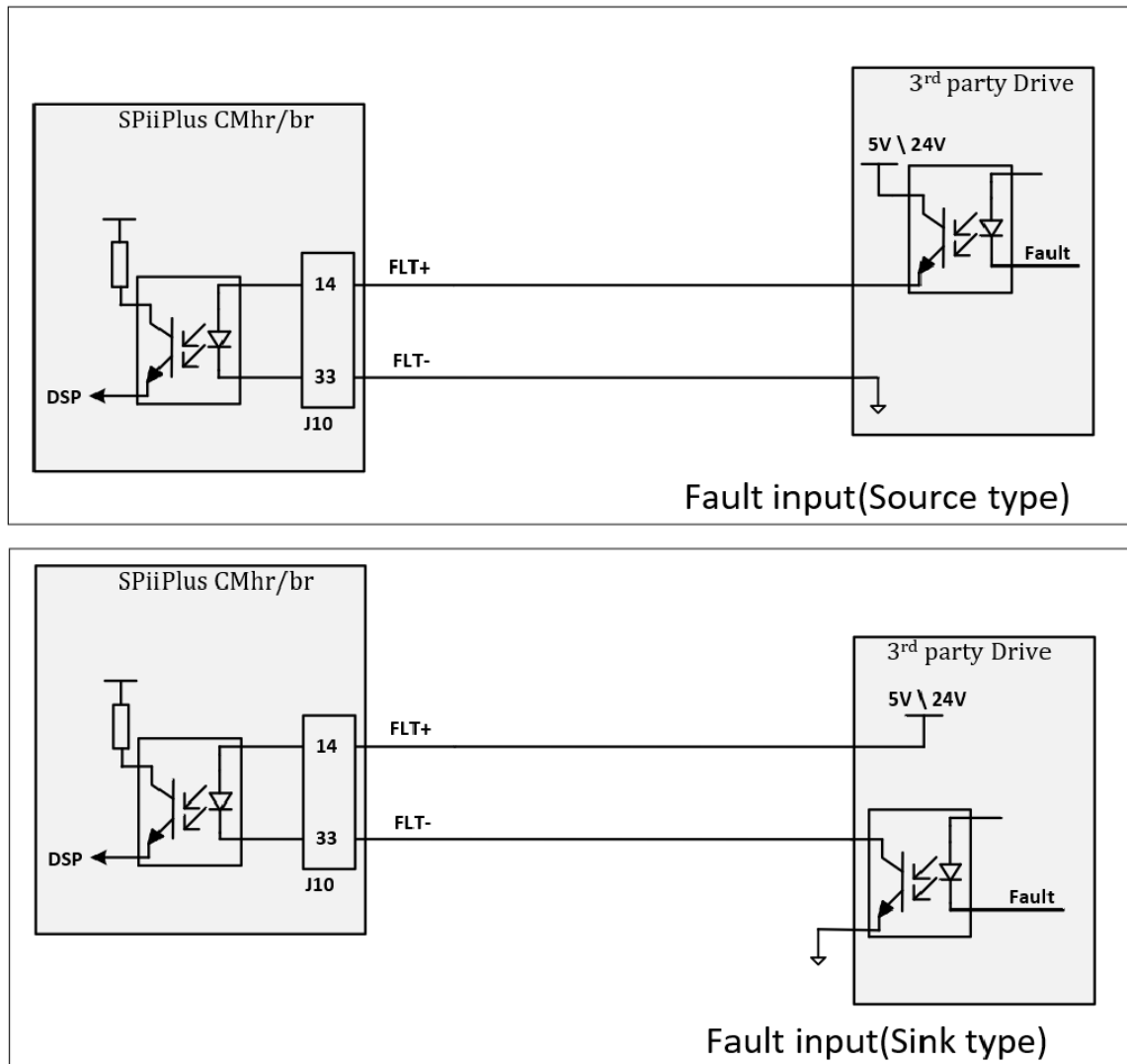

Figure 4-7. Fault signal electrical schematic, 'source' and 'sink' connectivity scheme.



Fault input voltage is detected automatically.

4.7 Position Event Generation (PEG)

The SPiiPlusCMxa supports advanced Position Event Generator (referred to also as Position Output Compare) output signals for synchronous random and incremental timing generation. The two PEG Pulses and eight PEG STATE signals can be associated with any of the incremental encoders, and can be programmed for polarity and shape. The product supports 3 PEG generators, each of which can be associated with the available encoders.

The Incremental PEG mode provides the ability to generate a series of evenly spaced fixed width pulses, starting and ending at predefined start and end points.

The Random PEG mode provides the ability to control a PEG Pulse and a four-bit STATE vector at pre-defined positions, out of a 1024 member user-defined array per each PEG-generator. Moreover, since the PEG signals from each engine can be 'OR'ed so that they all result in a signal coming out of a single interface, a maximal array of 3x1024 position points per selected axis (3072 points) is supported.



PEG does not work with absolute encoders.

For more details, see the *PEG and MARK Operations Application Notes*.

5. Power Supplies

The SPiiPlusCMxa is fed by two supply sources. The motors are fed either by a 100-240(±10%) VAC supply or by a 120 to 375 VDC supply. A 24VDC supplies power to the logic and control circuitry. Additionally, external voltage is provided for mechanical brake, digital outputs and for safety signals.

5.1 Control Supply

24Vdc (±10%), drawing maximally 2A.

5.2 Mechanical Brake

User supplied nominal 24Vdc (5-30Vdc), up to 3A.

5.3 Digital Input/ Output Supply

User provided 5Vdc (±10%) or 24Vdc (±20%), up to 0.8A. Detected automatically. Connected between the V_SUP_IO and V_RET_IO pins.

5.4 Safety Inputs Supply

User provided 5Vdc (±10%) or 24Vdc (±20%) up to 0.2A, detected automatically. Connected between the V_SUP_SFTY and V_RET_SFTY pins.

5.5 Drive Power Supply

The product is fed by a single phase or a 3 phase AC supply:

- > Single phase supply:
 - > SPiiPlus CM versions A and B: 100-240(±10%) VAC, 18A RMS-up to 4200W continuous, 7200W peak (for 1 second).
 - > SPiiPlus version C: (15/30Amp) (continuous/peak) current: 100-240(±10%) VAC, phase-to-phase
- > Three phase supply: 100-240(±10%) VAC, phase-to-phase. Current per phase of up to 18A RMS for a total of 7300W continuous power, and 14,600W peak power (1 second for all phases).
- > Regeneration: SPiiPlusCMxa provides an internal regeneration shunt resistor rated at 100Ω/100W (continuous). If required, an external shunt resistor (rated >13Ω) should be deployed.

5.6 Integrated Digital Drives

Quantity: One, two or three.

Type: PWM, digital current control with space vector modulation

PWM Frequency: 20 kHz.

Current Loop Sampling rate: 20 kHz.

Control Algorithm: PI

Drive short circuit capability: 5kA

Phase Currents (sine wave amplitude):

- > SPIIPlusCMxa -1/2/3-A: 5A continuous; 10A peak (1 second). Maximum power per axis for 240VAC three phase drive supply is 1390W continuous, 2760W peak.
- > SPIIPlusCMxa -1/2/3-B: 10A continuous; 20A peak (1 second). Maximum power per axis 240VAC three phase drive supply is 2760W continuous, 5420W peak.
- > SPIIPlusCMxa -1/2/3-C: 15A continuous; 30A peak (1 second). Maximum power per axis 240VAC three phase drive supply is 4100W continuous, 7900W peak.

Total Output Power, versions A, B, and C:

For single phase supply, 240VAC:

Continuous power of 2880W for types A, B and 3900W for C.

Peak power (1 second) of 6360W for A,B and 7220W for C.

For three phase supply, 240VAC:

Continuous power of 4100W for type A, 5000W for B, 6700W for C.

Peak power (1 second) of 8000W for A, 10700W for B, 16000W for C.

- > Input Voltage: 5Vdc ($\pm 10\%$) or 24Vdc ($\pm 20\%$), automatic detection.
- > Propagation Delay: <1msec.

6. Digital Inputs and Outputs

6.1 Digital Outputs

SPiiPlusCMxa line provides 8 single ended, opto-isolated, 5V(±10%) or 24V ±20%, with 0.1A per output, up to a total of 0.8A for 8 outputs. IO supply is externally user-provided, common to all signals. 'Source' and 'sink' type of digital output connection are shown. [Figure 6-1](#) and [Figure 6-2](#). The selection between the configurations is a function of a side-panel user-accessible jumper JP7. Refer to [Table 8-1](#) for the jumper's location and picture.

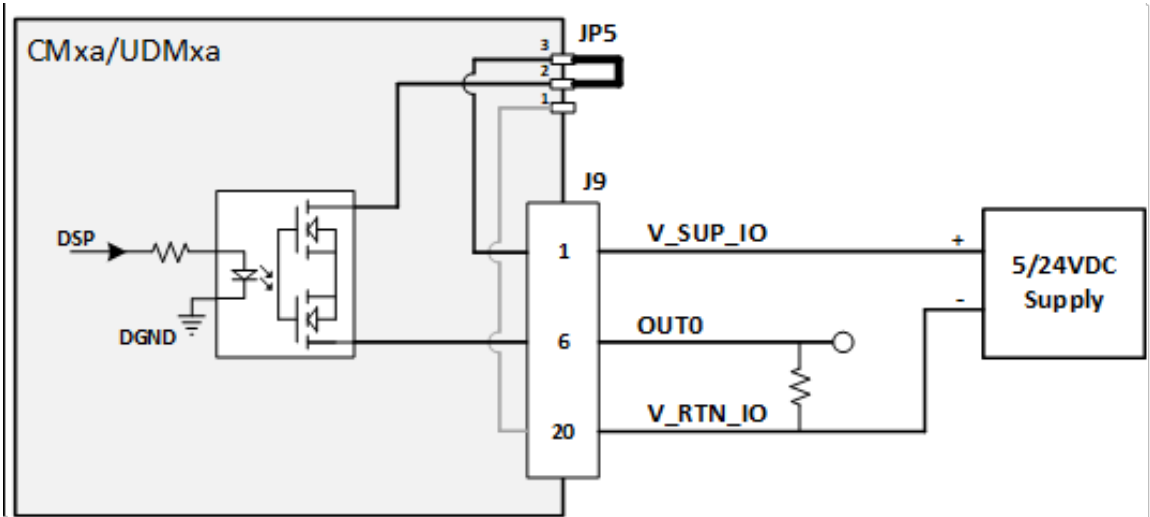

Figure 6-1. Digital Output Connection (source)

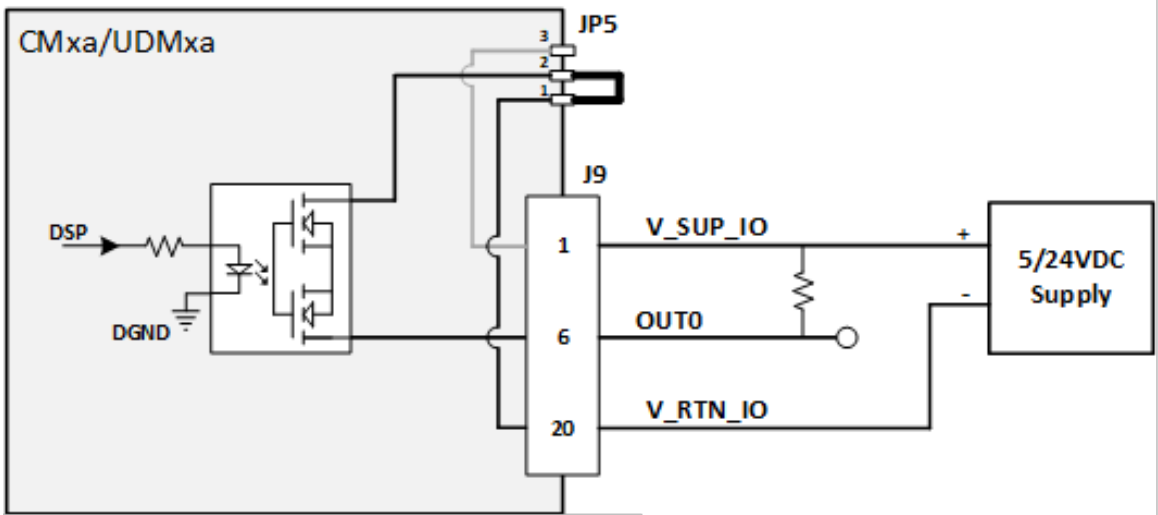

Figure 6-2. Digital Output Connection (sink)

Over current protection (per pin) is activated above 120mA, causing the output to enter a protected mode, without any message given to the user. The output self-recovers upon identifying a return to specified performance values.

6.2 Digital Inputs

SPiiPlusCMxa line provides 8 single ended, opto-isolated, 5Vdc ($\pm 10\%$) or 24Vdc ($\pm 20\%$), sink or source current driving inputs are available, as function of a side-panel user-accessible jumper J7. Refer to [Table 8-1](#) for location and picture. The digital input connection is shown in [Figure 6-3](#) and [Figure 6-4](#).

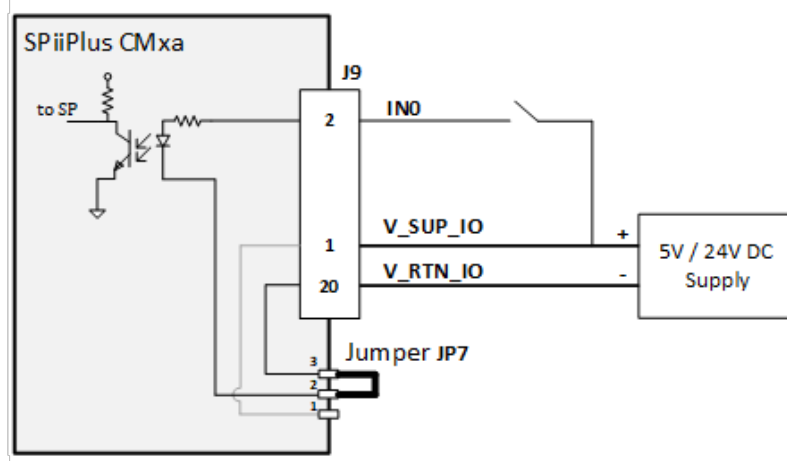

Figure 6-3. Source Digital Inputs

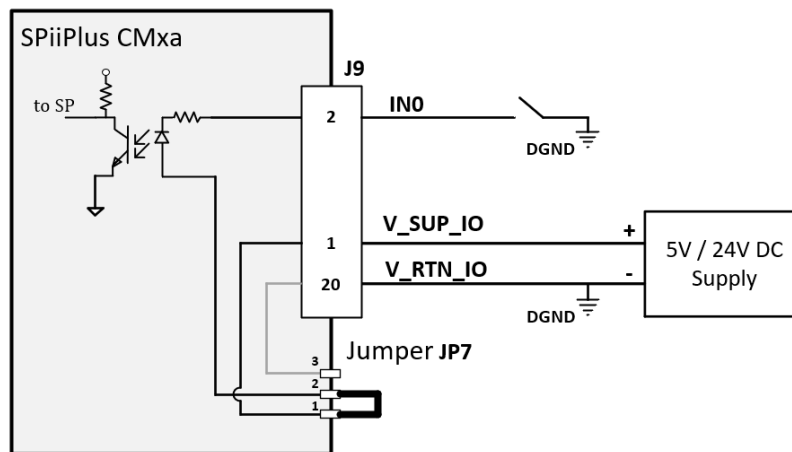

Figure 6-4. Sink Digital Inputs

IN4-IN6 are shared with limits for PD axes 6 and 7.

6.3 Hall Sensors

One Hall sensor per drive (set of 3 single-ended, current driving lines) is available. The lines are opto-isolated with current sensitivity of 7mA. The connection for a HALL sensor is shown in [Incremental Digital AqB Encoder Connections](#).

6.4 Registration MARK Inputs

There are four inputs that can be configured as MARK. If these inputs are not used for MARK, they can be used as General Purpose inputs.

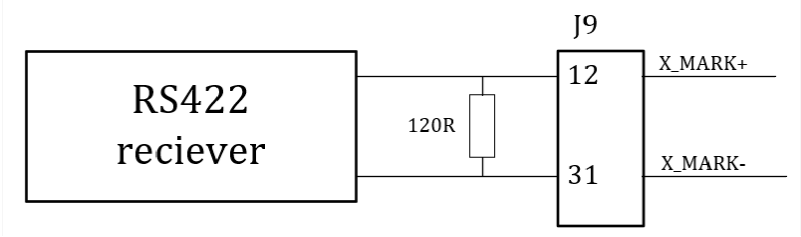

Figure 6-5. Differential Connection for MARK1 Input

The MARK input voltage is 5Vdc ±10% and its signal propagation rate is < 0.1µsec. The MARK signals are designed with ESD protection.

7. Analog Inputs and Outputs

7.1 General Purpose Analog Inputs

SPiiPlusCMxa line provides six differential $\pm 10V \pm 5\%$ inputs with 12-bit or 16-bit accuracy, with hardware low-pass filter set to 250 kHz and maximal sampling rate of 20kHz. The General Purpose Analog Input connections are shown below.

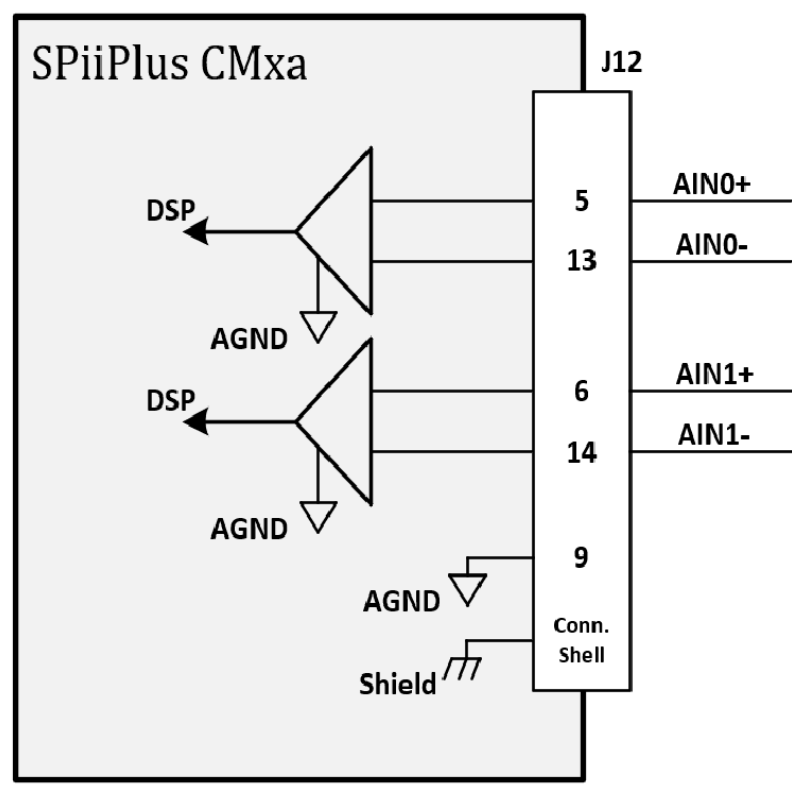

Figure 7-1. General Purpose Analog Inputs



The user should ensure that the analog input's signal range does not exceed the specified range of $\pm 10V$. Higher signals may cause abnormal behavior of the drive and affect its performance.

7.2 General Purpose Analog Outputs

SPiiPlusCMxa line provides two General Purpose Analog Outputs. The outputs are characterized by 10-bit resolution, differential $\pm 10V \pm 5\%$, 50mV maximal offset, with 50mVp_p maximal ripple, and linearity better than 1%. Minimal 10K Ω load required.

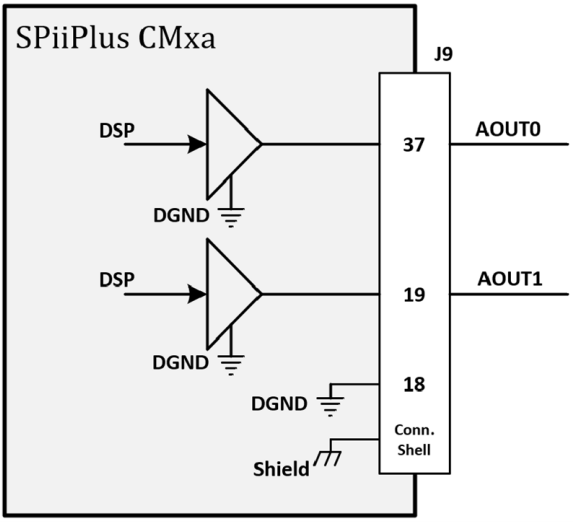

Figure 7-2. Analog output schematic diagram

8. Other Inputs

8.1 Right and Left Limit Inputs

Right Limit and Left Limit inputs per axis are available. The limit connections are shown in [Figure 8-1](#) and [Figure 8-2](#).

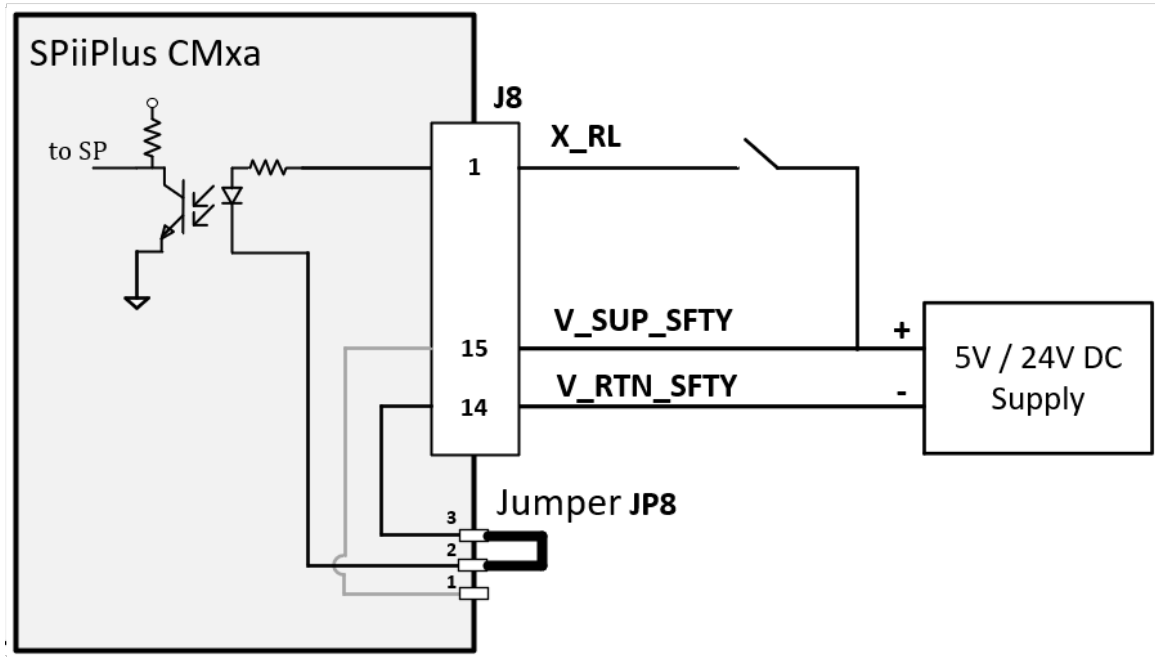

Figure 8-1. Right Limit (Source) schematic diagram

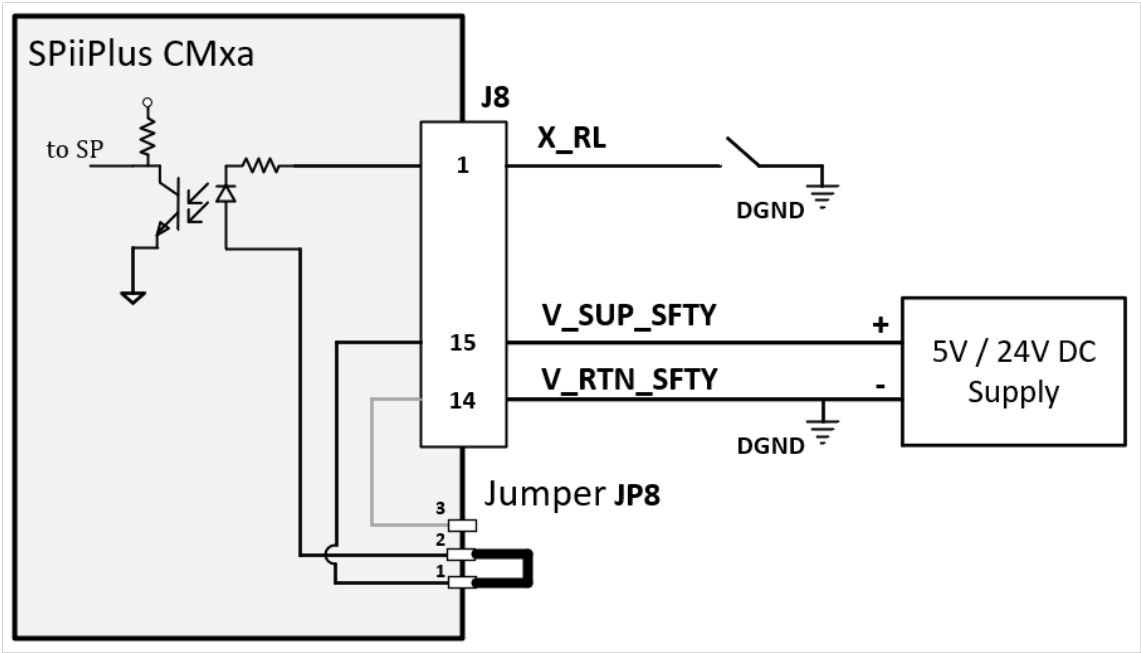



Figure 8-2. Right Limit (Sink) schematic diagram

 When voltage is supplied to V_SUP_SFTY and V_RTN_SFTY the device automatically determines the voltage that the user must supply to the limit inputs.

An external user-accessible side-panel jumper (J8) enables configuration for sink or source for right limit and left limit inputs and for the emergency stop. For location of J8, see [Figure 8-1](#)

8.2 Emergency Stop

The Emergency Stop input is a single, opto-isolated signal, fed from a 5V or 24V supply and activated at above 14mA.

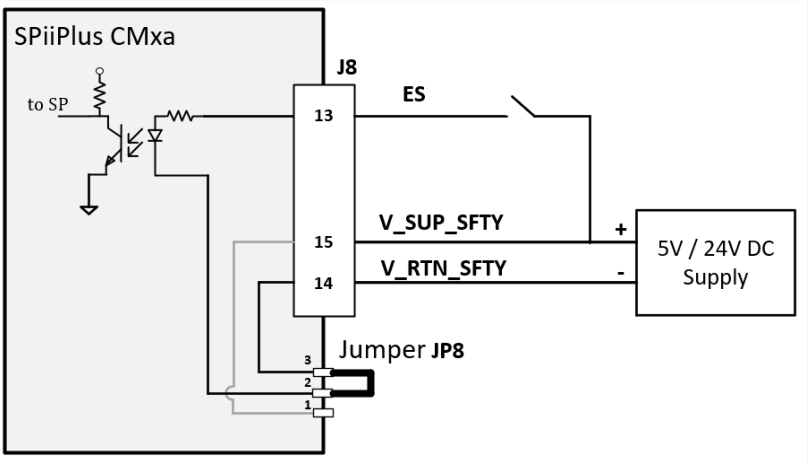

Figure 8-3. Emergency Stop Source Input

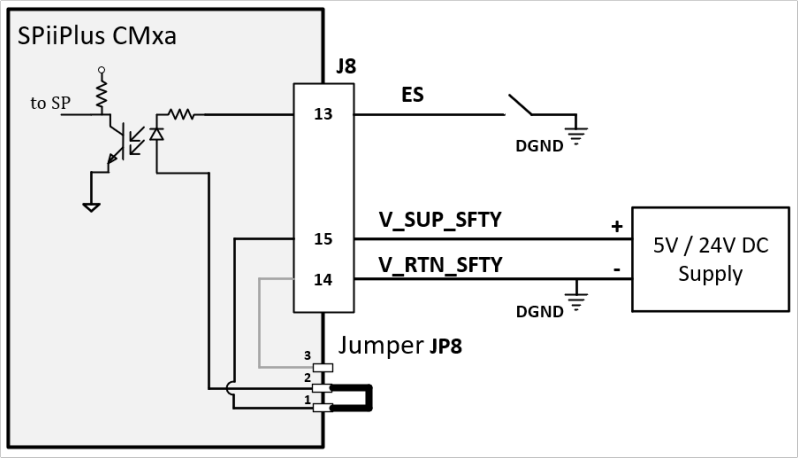



Figure 8-4. Emergency Stop (Sink) schematic diagram

 When voltage is supplied to V_SUP_SFTY and V_RTN_SFTY the device automatically determines the voltage that the user must supply to the limit inputs.

8.3 STO Input Connections

Two STO inputs are available. Figure 8-5 illustrates connection of the STO inputs.

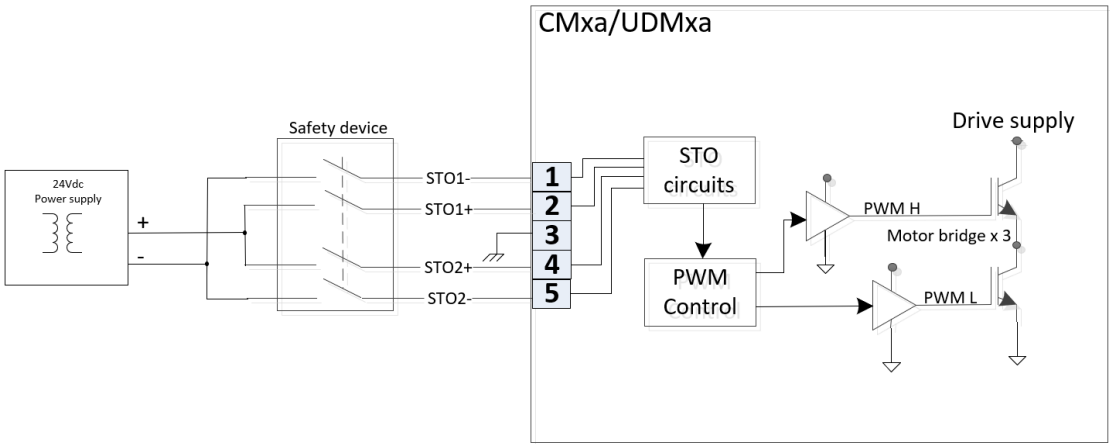

Figure 8-5. STO Inputs

8.4 Motor Over Temperature Fault

The SPIIPlusCMxa line provides one input signal per axis for connecting Motor Over Temperature fault sensors. The signal is single-ended, opto-isolated and referenced to a common ground for all faults as shown in Figure 8-6.

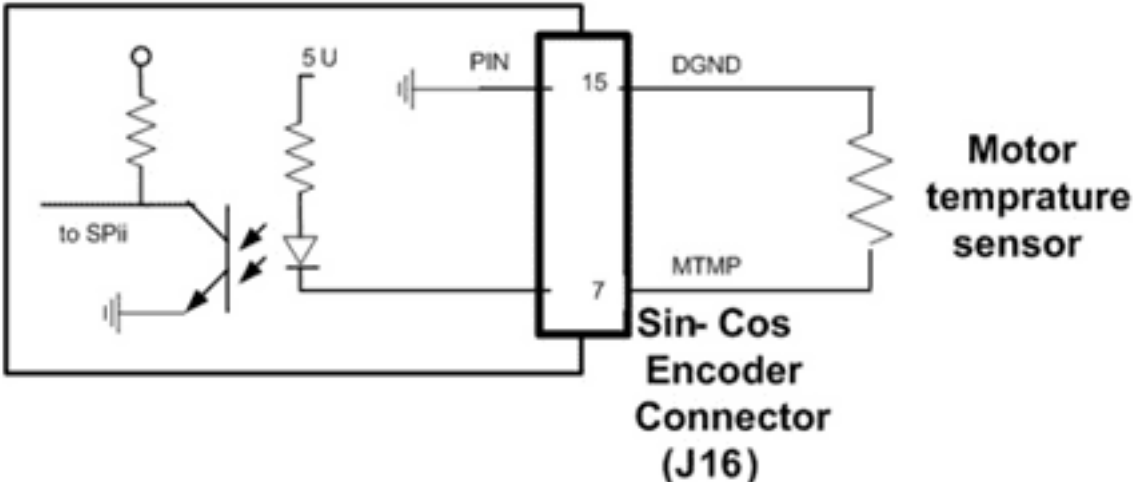

Figure 8-6. Motor Over Temperature Connection

Indication is ON when the motor PTC is > 10kΩ, and is OFF when motor PTC impedance is < 1kΩ.

8.5 SPIIPlusCMxa Jumpers

The SPIIPlusCMxa devices have three jumpers: JP5, JP7, and JP8, the locations of which are shown in Figure 8-7.



Figure 8-7. Jumper Locations

The function of each jumper is given in Table 8-1.

Table 8-1. SPiiPlusCM Jumpers

	Function	Default	Optional setting
JP5	Digital outputs SINK/SOURCE	SINK, 1-2	Source, 2-3
JP7	Digital inputs SINK/SOURCE	SINK, 1-2	Source, 2-3
JP8	Safety inputs SINK/SOURCE	SINK, 1-2	Source, 2-3

8.6 Jumper Configuration for Sink and Source

The factory default configuration of jumpers JP5, JP7, and JP8 is Sink (pins 1 and 2 are connected). The SPiiPlusCMxa provides configuration of digital inputs, digital outputs, and safety inputs.

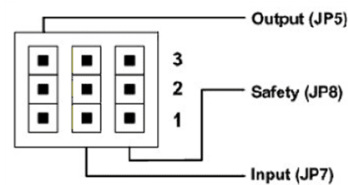

Figure 8-8. Sink or Source Jumper Configuration

- > To set Sink configuration, install a jumper between pins 1 and 2.
- > To set Source configuration, install a jumper between pins 2 and 3.

8.7 SPiiPlusCMxa DIP Switches

The SPiiPlusCMxa has 6 DIP switches, shown in [Figure 8-9](#), that are used for setting the EtherCAT ID of the unit.



Figure 8-9. SPiiPlusCMxa line DIP Switches

The number is set by positioning the switches in either the OFF or ON position, where:

OFF - "0"

ON - "1"

DIP switch 1 is the least significant digit.

For example, if the switches are set as follows:

Switch 1 – OFF
Switch 2 – ON
Switch 3 – OFF
Switch 4 – ON
Switch 5 – OFF
Switch 6 – ON

The node number is: 101010 (or 42 in decimal).

9. Fault Indications

The table below summarizes all faults detected by the product and the resulting indications to the user.

All faults can be read as ACSPL+ variables within a user's application code.

The table lists warning messages displayed at the MMI for some of the messages, as well as the action taken by the controller upon critical fault detection.

Table 9-1. Table 6: Faults and Warning Messages

Fault	Fault conditions	Panel Indicators (LED)	MMI warning message and action taken
Bus overvoltage	DC bus voltage > 420Vdc	None	Warning message: Power supply too high. All internal drives are disabled.
Bus under voltage	DC bus voltage < 75Vdc	None	Warning message: Power supply too low. All internal drives are disabled.
Phase-Loss (for Three-Phase AC Input Supply Only)	One AC phase missing	None	Warning message: Power Down. All internal drives are disabled.
Power loss (1 phase)	AC power is missing	Bus Voltage(VP) OFF when AC power is lost	Warning message: Phase-Loss All internal drives are disabled.
Drive over-temp	Temperature on heat sink >95±5°C	None	Warning message: Temperature too high. All internal drives are disabled.

Fault	Fault conditions	Panel Indicators (LED)	MMI warning message and action taken
Short circuit Between Phases or Phase to Ground	Current in one of the integrated digital drive output phases exceed the maximum value	None	
Drive Over current.	Current in one of the integrated digital drive outputs exceeds the over current protection level	None	
Motor over-temp	Over temperature protection is On: Impedance between pin to ground is above 10K Ω . Over temperature protection is Off: Impedance between pin to ground is below 1K Ω	None	All internal drives are disabled.
Encoder faults	Disconnections or incorrect order in one or more encoder channels.	None	
Drive not Ready	Triggered when drive enable command is sent within five seconds of drive power on	None	

Fault	Fault conditions	Panel Indicators (LED)	MMI warning message and action taken
Power Supply Not Ready		None	User is notified by MMI if attempting to operate drive enable during first 4.5 - 5.5 sec ('soft start')
Communication lost		Red LED: Lost communication.	

10. Grounding and Shielding

Figure 10-1 depicts the recommended scheme for shielding, cable connections and type of grounding.

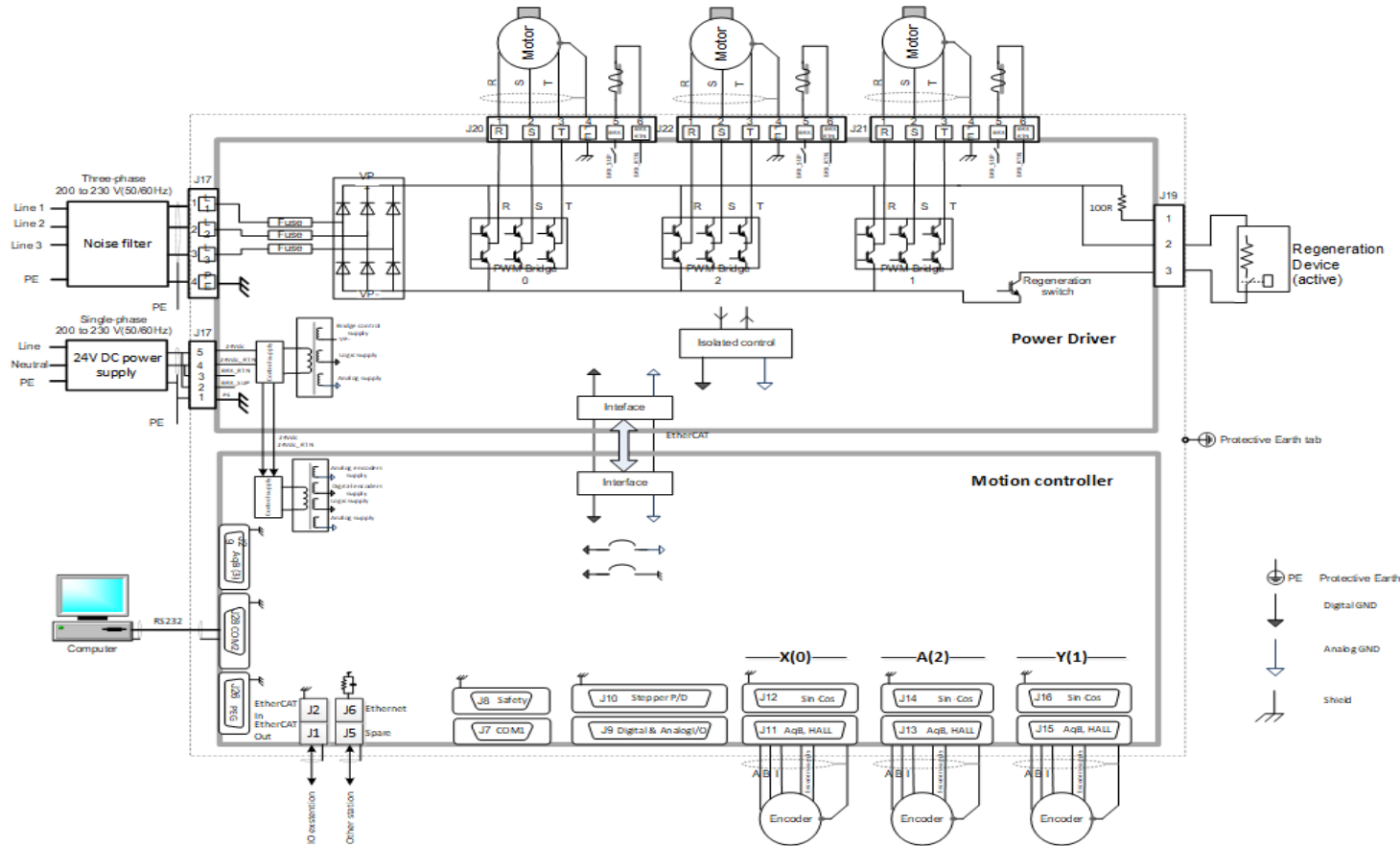

Figure 10-1. Grounding and Shielding

11. Personal Safety Guidelines

Make sure that the following guidelines and procedures are addressed and observed prior to powering and while handling any of the network elements. Observing these procedures is crucial in order to achieve safe and optimal operation of ACS networking provisions.

Installation and maintenance must be performed by qualified personnel only. Such a person must be trained and certified to install and maintain high power electrical and electro-mechanical equipment, servo systems, power conversion equipment and distributed networks. Prior to powering up the system, ensure that all network components are properly installed mechanically, properly grounded and that all attached power and signal cables are in good operating conditions. Maintenance should be performed only after the relevant network element has been powered down, and all associated and surrounding moving parts have settled in their safe mode of operation. Certain drives require longer times in order to fully discharge.



In order to ensure that the internally stored energy has been fully discharged to a safe level that will not harm personnel exposed to the energy, allow a minimum of 5 minutes after powering down the until handling or touching the unit. Special care should be provided while applying, removing or touching connector J10 that contains (VBUS+ and VBUS-) bus voltage carrying wires.

Follow the hardware guide of each element and observe the residual discharge time specified. Avoid contact with electrostatic-sensitive components and take the required precautions.



All power terminals remain live for at least 5 minutes after the mains have been disconnected.

The SPiiPlusCMxa is powered up as long as an ACS inlet is connected to it. Therefore it is the responsibility of the user to provide an in-series switch or circuit breaker that disconnects all power-carrying signals which is readily and rapidly accessible to the operator. The disconnecting device must meet the requirements of IEC60947-1 or IEC60947-3 and the current rating must be not more than 20A. The disconnecting device must be in close proximity to the equipment and within easy reach of the operator and be clearly marked as the disconnecting device for the SPiiPlusCMxa. A power cord with conductor area of not less than 0.75mm, with a voltage rating of not less than 300V, rated to 105°C or more, and complying with IEC60227 or IEC60245 must be used for the AC drive supply input. Only the Green –Yellow wire of the cable is to be used for connection to the protective conductor terminal.

12. Dimensions and Installation

The dimensions of the SPiiPlusCMxa products are shown in the following figures.

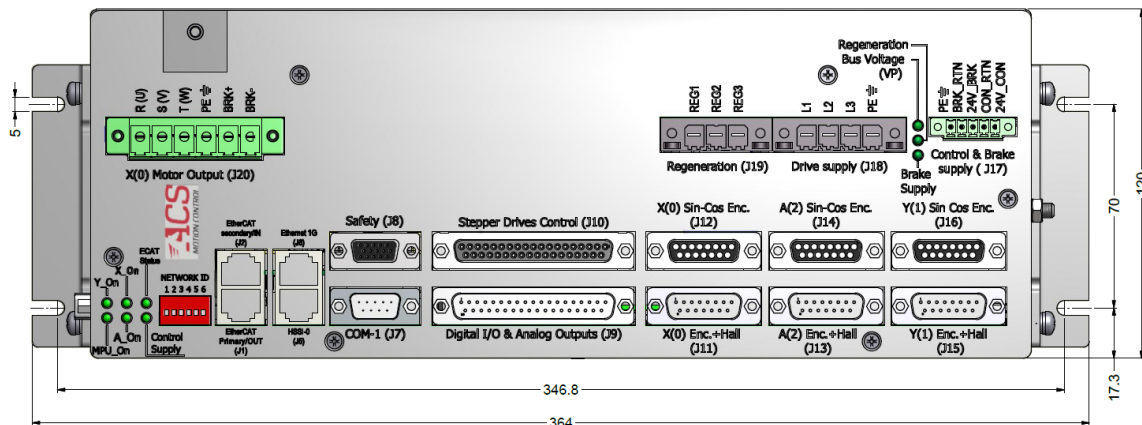

Figure 12-1. SPiiPlusCMxa Front

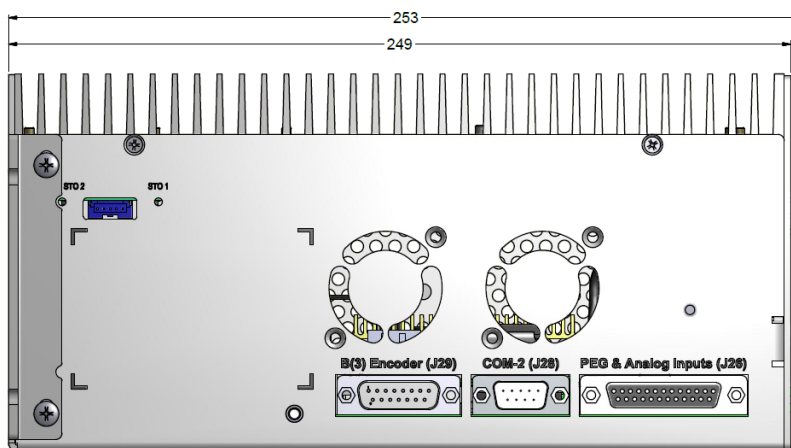

Figure 12-2. SPiiPlusCMxa Side

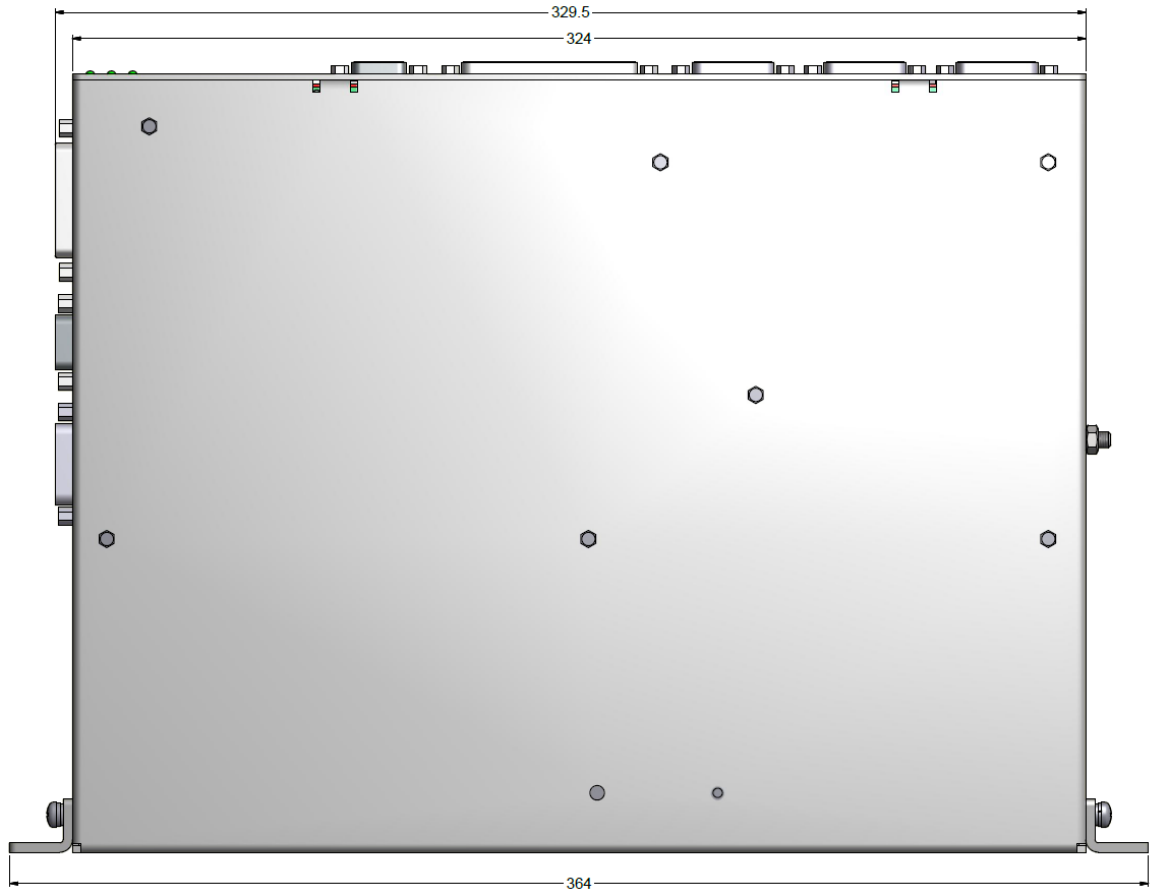

Figure 12-3. SPiiPlusCMxa Bottom

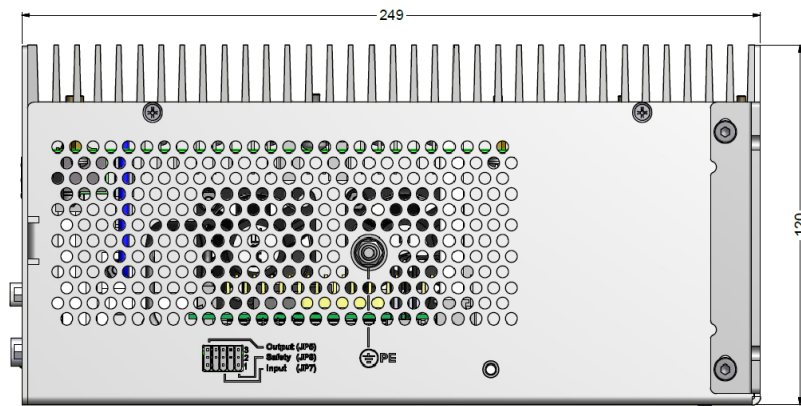

Figure 12-4. SPiiPlusCMxa Rear

13. SPIIPlusCMxa Specifications

This section presents the specifications for the SPIIPlusCMxa product line.

13.1 Control Supply Input Power

	Description	Remarks
Signal Designation	24V 24V_RTN	When it is needed to ensure that the motors are not powered, the Drive power supply should be removed. The Control supply, however, should stay connected.
Quantity	1	
Type	DC power supply for all internal circuits	
Input Voltage	Nominal voltage: 24Vdc > Minimum voltage: 21.6Vdc > Maximum voltage: 26.4Vdc	
Input Current	2A @ 21.6V	
Protection	> Input Reverse polarity > Output Short current	

13.2 Brake Supply Input

	Description	Remarks
Signal Designation	24V_BRK BRK_RTN	
Quantity	1	
Type	DC power supply for mechanical brake	
Input Voltage	5-30Vdc	
Input Current	3A	
Protection	Short and over current.	

13.3 Drive Power Supply

	Description	Remarks
Signal Designation	L1, L2(N), L3 PE	
Quantity	1	
Type	Single or three phases, rectifier, motor drive supply with regeneration circuit.	
Input Voltage Range, [Vrms]	AC power supply: 100-240 (+/-10%) VAC, single or three phase DC power supply: 120-375 VDC	
Frequency	Nominal frequency: 50-60Hz	
Input Current (Continuous/Peak), [Arms for AC input, ADC for DC input]	For single phase input 240VAC: 1. Drive "A": 18 / 37 2. Drive "B": 18 / 37 3. Drive "C": 24/ 42 For three phase input 240VAC and 340Vdc: 1. Drive "A": 15 / 27 2. Drive "B": 18 / 37 3. Drive "C": 24/ 54	

	Description	Remarks
Input Power (Continuous/Peak), [W]	For single phase input 240Vac: 1. Drive "A": 4325 / 8910 2. Drive "B": 4325 / 8910 3. Drive "C": 5810 / 10084 For three phase input 240Vac: 4. Drive "A": 6161 / 11331 5. Drive "B": 7483 / 15172 6. Drive "C": 10026 / 22536	
Phase in series fuse	20A	
DC bus voltage (power supply output) at continuous/peak input current, (V)	336VDC For single phase input 240Vac: 1. Drive "A": 315 / 284 2. Drive "B": 315 / 284 3. Drive "C": 307 / 275 For three phase input 240Vac: 1. Drive "A": 328 / 320 2. Drive "B": 326 / 314 3. Drive "C": 320 / 294	Maximum value for 240Vac input at no load Minimum values for all axes operating simultaneously
Output Voltage [V]	DC bus voltage (power supply output), Max = (Vac in) x 1.41 x 97%	maximum 375V

	Description	Remarks
Bus voltage drop at continuous/peak input current, (V)	For single phase input 240Vac: 1. Drive "A": 23 / 57 2. Drive "B": 23 / 57 3. Drive "C": 32 / 67 For three phase input 240Vac: 1. Drive "A": 9 / 18 2. Drive "B": 11 / 24 3. Drive "C": 18 / 47	
Inrush Current	Maximum inrush current value is 3.75A rms measured for the first 20ms after power supply input voltage is applied.	
Protection	<ul style="list-style-type: none"> > Power down: AC input supply is disconnected or one AC input fuse is blown > Under voltage: 80V±5% (76 – 84V) > Power Supply Not Ready (Soft Start resistor protection): generates fault during the Soft Start period 4.5 – 5.5 Sec > Over voltage: 440±5% (422 – 467V) > Phase lost: one of the AC input supply phases is disconnected or fuse is blown. 	

13.4 Power Bridge (Per Axis)

	Description	Remarks
Signal Designation	\$_R \$_S \$_T	One set per axis
Quantity	3	
Type	PWM three phase power bridge	
Motor configuration	DC motor 2- or 3-phase motor 2-phase step motor	
Output Current [A]	5/10A Continuous/Peak sine amplitude (Model A) 10/20A Continuous /Peak sine amplitude (Model B) 15/30A Continuous /Peak sine amplitude (Model C)	The peak current is for 1 second
Output voltage, phase-to-phase (Vrms)	229 For single phase input 240VAC: 1. Drive "A": 214 / 193 2. Drive "B": 214 / 193 3. Drive "C": 208 / 187 For three phase input 240VAC: 1. Drive "A": 223 / 218 2. Drive "B": 222 / 214 3. Drive "C": 218 / 200	Maximum value for 240Vac input at no load Minimum values for all axes operating simultaneously

	Description	Remarks
Output power per axis, continuous/Peak (W)	For single phase input 240Vac: 1. Drive "A": 1360 / 2639 2. Drive "B": 2639 / 4952 3. Drive "C": 3836 / 6937 For three phase input 240Vac: 1. Drive "A": 1390 / 2757 2. Drive "B": 2757 / 5423 3. Drive "C": 4081 / 7917	
Total output power for all axes operating simultaneously, continues/Peak (W)	For single phase input 240Vac: 1. Drive "A": 2885 / 6357 2. Drive "B": 2885 / 6357 3. Drive "C": 3905[2] / 7218 For three phase input 240Vac: 1. Drive "A": 4102 / 7999 2. Drive "B": 4982[1] / 10727 3. Drive "C": 6678[2] / 15999	
Heat dissipation per axis , W)	1. Drive "A": 33 2. Drive "B": 67 3. Drive "C": 102	For 240Vac supply maximum values
Protection	Short current (phase-to-phase or phase to ground): <ul style="list-style-type: none"> > For 5/10A axis: 25A ±5% > For 10/20A axis: 50A ±5% > For 15/30A axis: 60A ±5% Over current: <ol style="list-style-type: none"> 1. No inherent motor O/L protection provided as per CEC Part 1 and NEC 2. Trip current value activates the over current protection within 60 sec: <ul style="list-style-type: none"> > For 5/10A axis: 5.4A ±5% sine amplitude (3.8Arms) 	

	Description	Remarks
	<ul style="list-style-type: none"> > For 10/20A axis: 10.7A ±5% sine amplitude (7.6Arms) > For 15/30A axis: 16.1A ±5% sine amplitude (11.4Arms) <p>3. 200% of the nominal current value activates the over current protection within 1 sec:</p> <ul style="list-style-type: none"> > For 5/10A axis: 10A ±5% sine amplitude (7.1Arms) > For 10/20A axis: 20A ±5% sine amplitude (14.1Arms) > For 15/30A axis: 30A ±5% sine amplitude (21.2Arms) <p>4. 300% of the nominal current value activates the overcurrent protection within 5 msec (solid state protection):</p> <ul style="list-style-type: none"> > Drive hardware protection within 5msec For 5/10A axis: 15A ±5% > Drive hardware protection within 5msec for 10/20A axis: 30A ±5% > Drive hardware protection within 5msec for 15/30A axis: 45A ±5 <p>Over temperature: >95°C ±5% on heat sink</p>	

13.5 AqB Digital Encoder

	Description	Remarks
Signal Designation	A: #_CHA± B: #_CHB± I: #_CHI±	
Quantity	4	One set for axes 0(X), 1(Y), 2(A) and 3(B)

	Description	Remarks
Type	Differential, RS422 compatible	
Maximum Input Frequency	12.5 MHz	12.5MHz A & B input frequency appropriate to 50 million quadrature counts per second.
Input Termination	120 Ω	On each signal pair
Encoder Supply	5.1V-5.35V 1A	1A total current available for all (up to four) encoders
Protection	Encoder not connected, encoder error	Phase A detection only

13.6 SIN-COS Analog Encoder (Optional)

	Description	Remarks
Signal Designation	#_SIN \pm #_COS \pm #_SC_I \pm	
Quantity	3	For axes: 0(X), 1(Y) and 2(A)
Type	Analog Differential input, Encoder voltage range 1 Vptp \pm 10% Input Voltage range: 1.25 Vptp	
Maximum Input Frequency	< 250 KHz	
Input Termination	120 Ω	
Resolution	> 12 bit > or 16 bit (optional)	

	Description	Remarks
Multiplication	12 bit resolution: X4 to X4,096 16 bit resolution: up to X65536	
Compensations	Offset(HW for UDMHP only): Gain(SW) Phase(SW) Range: $\pm 0.320V$ Resolution: 8-bit	Gain and phase: SW implementation
Encoder Supply Range	5.1 V - 5.35 V 1 A	1A total current available for all (up to three) encoders
Protection	Encoder error and not connected	SW implementation

13.7 Absolute Encoder (Optional)

	Description	Remarks
Signal Designation	#_CHA #_CHB	
Quantity	3	For axes: 0(X), 1(Y) and 2(A)
Type	EnDat2.2, Smart-Abs, Panasonic, BiSS-C (from V2.30)	
Interface	RS485/RS422	
Input Termination	120 Ω	
Encoder Supply Range	5.1 V - 5.35 V 1 A	1A total current available for all [up to four including digital incremental 3(B)] encoders

13.8 STO Inputs

	Description
Designation	STO1± STO2±
Quantity	2 inputs. Switch off all axes simultaneously. One shuts off the upper part of the motor bridge and one the lower part of.
Interface	24V isolated, two terminal for each input
Input current (per input pin)	<70mA.
Behavioral	No current=drive off.

13.9 HALL Inputs

	Description	Remarks
Signal Designation	\$_HA \$_HB \$_HC	
Quantity	3	One set for each axis.
Type	Opto-isolated, Source input type, (open cathode)	DGND referenced.
Input Current	< 7 mA current	

13.10 Mechanical Brake High Power

	Description	Remarks
Signal Designation	\$_BRK±	
Quantity	3	One per axis, on driver board connectors

	Description	Remarks
Type	5-30 V, opto-isolated, source	
Output Current	1 A per output	
Reference Supply	Brake supply	
Protection	Short circuit	

13.11 Mechanical Brake Logic Signal

	Description	Remarks
Signal Designation	#_MBRK±	
Quantity	3	One per axis
Type	opto-isolated, sink	Operates from V_SUP_IO and V_RET_IO (5 V ±10% or 24 V ±20%,)
Output Current	50 mA per output	
Protection	Short circuit	

13.12 Limit Inputs

	Description	Remarks
Signal Designation	#_RL #_LL	
Quantity	2 per axis	P/D axes 6 and 7 without dedicated limits inputs. GP IO 4-7 can be used if needed
Type	Single-ended, opto-isolated, sink/source	Operates from V_SUP_SFTY and V_RET_SFTY (5 Vdc ±10% or 24 Vdc ±20%,)
Input Current	4-14 mA	

13.13 E-Stop Inputs

	Description	Remarks
Signal Designation	ES	
Quantity	1	
Type	Single-end, opto-isolated	Operates from V_SUP_SFTY and V_RET_SFTY (5 Vdc ±10% or 24 Vdc ±20%,)
Input Current	4-14 mA	

13.14 Digital Inputs

	Description	Remarks
Signal Designation	IN0...IN7	IN4-IN6 shared with limits for PD axes 6 and 7
Quantity	8	
Type	Single-ended, opto-isolated, sink/source	Operates from V_SUP_IO and V_RET_IO (5 V ±10% or 24 V ±20%,)
Input Current	4--14 mA	

13.15 Digital Outputs

	Description	Remarks
Signal Designation	OUT0...OUT7	
Quantity	8	
Type	Single-ended, opto-isolated, sink/source	Operates from V_SUP_IO and V_RET_IO (5 V ±10% or 24 V ±20%,)
Output Current	100 mA per output for total of 800 mA for all outputs	
Protection	Short circuit	

13.16 MARK Inputs

	Description	Remarks
Signal Designation	#_MARK1± #_MARK2±	Flexible allocation, see <i>PEG and MARK Operations Application Notes</i>
Quantity	4	Two physical inputs per axis X and Y
Type	Differential, RS422	
Input Impedance	120 Ω	

13.17 PEG Pulse

	Description	Remarks
Signal Designation	#_PEG±	Incremental and Random , see <i>PEG and MARK Operations Application Notes</i>
Quantity	2 dedicated outputs available, with flexible assignment of signals.	
Type	Differential, RS422 compatible	

13.18 PEG STATE Pulse

	Description	Remarks
Signal Designation	#_STATE0± #_STATE1± #_STATE2± #_STATE3±	
Quantity	8 dedicated outputs available, with flexible assignment of signals.	
Type	Differential, RS422 compatible	

13.19 General Purpose Analog Inputs

	Description	Remarks
Signal Designation	AIN_#±	Where # is 0 through 5
Quantity	6	
Type	Differential input, ±10V±5%	Shares the same input with SIN-COS encoders, each SIN-COS uses two inputs.
Maximum Input Frequency	Low-pass filtered to 250kHz. Maximal sampling rate of 20kHz	
Resolution	12-bit ±10 V 16-bit ±10 V (optional)	
Offset	< 100 mV (measured with 0 V input)	

13.20 General Purpose Analog Outputs

	Description	Remarks
Signal Designation	AOUT_#±	
Quantity	2	
Type	Single-end, ±10 V ±5%	
Resolution	10 bit	
Offset	±50 mV	SW compensated
Minimum Output Load	10 KΩ	

13.21 Motor Over Temperature

	Description	Remarks
Signal Designation	#_OVER_T	
Quantity	3	

	Description	Remarks
Type	Single-ended, opto-isolated Reference: \$_MTMP_RTN	
Threshold	Over temperature protection is on, when the impedance between \$_Motor_OVER pin to ground is above 10 K Ω Over temperature protection is off, when the impedance between \$_Motor_OVER pin to ground is below 1 K Ω	

13.22 External P/D Drive Support (Option)

	Description	Remarks
Signal Designation	\$_Pulse \$_Dir \$_ENA \$_FLT	
Quantity	4	
Type	P/D signals: Differential, RS422 Enable signals: Opto-isolated, two terminal with Max current and protection Fault signals: Opto-isolated, two terminal	Operates from external supply 5 Vdc \pm 10% or 24Vdc \pm 20%
Maximum Frequency	5,000,000 pulses/second	
Minimum Pulse Width	80nS	
Maximum Pulse Width	81.88 μ S	

13.23 Ethernet Port

	Description	Remarks
Signal Designation	Receive: ET_RXD_2± Transmit: ET_TXD_1± Bidirectional: ET_BID_3±, ET_BID_4±	
Quantity	1	
Type	Ethernet protocol	
Speed	100/1000 Mbps	

13.24 EtherCAT Ports

	Description	Remarks
Signal Designation	Transmit: TX± Receive: RX±	
Quantity	2	"Primary" and "Secondary" ports – when Master of EtherCAT network
Type	EtherCAT protocol	
Speed	100 Mbps	

13.25 Environment

Operating	Ambient temperature: 0 to +40°C max. Refer to operating condition section.
Storage	Ambient temperature: -25 to +60°C max
Humidity	5% to 90% non-condensing

13.26 Applicable Standards

The SPIIPlusCMxa Dual Axis Control Module meets the requirements of the following standards:

EMC	<ul style="list-style-type: none"> > EN61326-3-1 under 2014/30/EU directive (STO) > EN61800-3 EN61500-5-2 > SEMI F47-0200
Safety	<ul style="list-style-type: none"> > 61800-5-1 > UL-61800-5-1
Functional Safety	<ul style="list-style-type: none"> > EN61800-5-2 (defines STO) > ISO13849 (defines PLe and CAT3) > EN61508 (defines SIL3)

14. SPiiPlusCMxa Connectors

14.1 J6 – Ethernet Connector

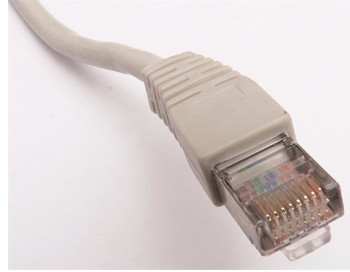

Figure 14-1. RJ45 Ethernet Mating Connector

Label: Ethernet (J6)

Connector Type: RJ45

Mating Type: Ethernet plug

Table 14-1. J1 Connector Pinout

Pin	Name	Description
1	TXD_1+	Transmit Data 1 +
2	TXD_1-	Transmit Data 1 -
3	RXD_2+	Receive Data 2 +
4	BID_3+	Bi-directional 3 +
5	BID_3-	Bi-directional 3 -
6	RXD_2-	Receive Data 2 -
7	BID_4+	Bi-directional 4 +
8	BID_4-	Bi-directional 4 -

14.2 J1,J2 – EtherCAT Connectors

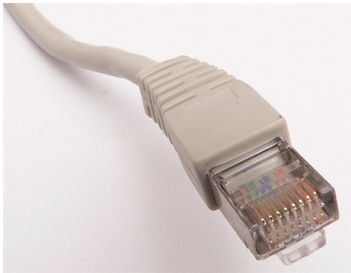

Figure 14-2. EtherCAT RJ45 Mating Connector

Label: EtherCAT OUT (J1)
EtherCAT In (J2)
Connector Type: RJ45
Mating Type: Ethernet plug

Table 14-2. J1 Connector Pinout

Pin	Name	Description
1	TD+	Positive transmit signal
2	TD-	Negative transmit signal
3	RD+	Positive receive signal
4	N/C	Not connected
5	N/C	Not connected
6	RD-	Negative receive signal
7	N/C	Not connected
8	N/C	Not connected

14.3 J8 – Safety Connector



Figure 14-3. Mating Connector for J8

Label: Safety (J8)

Connector Type: DB15 high density female

Mating Type: DB15 high density male

Table 14-3. J8 Connector Pinout

Pin	Name	Description
1	X(0)RL	X(0) axis right limit
2	X(0)LL	X(0) axis left limit
3	Y(1)RL	Y(1) axis right limit
4	Y(1)LL	Y(1) axis left limit
5	A(2)RL	A(2) axis right limit
6	A(2)LL	A(2) axis left limit
7	Not used	B(3) axis right limit
8	Not used	B(3) axis left limit
9	Z(4) PDO_RL	Pulse/Dir axis 4 right limit
10	Z(4) PDO_LL	Pulse/Dir axis 4 left limit
11	T(5) PD1_RL	Pulse/Dir axis 5 right limit
12	T(5) PD1_LL	Pulse/Dir axis 5 left limit
13	ES	Emergency stop
14	V_RTN_SFTY	Safety supply return
15	V_SUP_SFTY	Safety supply 5/24Vdc

14.4 J9 – Digital & Analog I/O Connector



Figure 14-4. J9 Mating Connector

Label: J9 I/O

Connector Type: DB37 male

Mating Type: DB37 female

Table 14-4. J9 Connector Pinout

Pin	Name	Description
1	V_SUP_IO	Digital I/O supply 5/24Vdc
2	IN0	Digital input 0
3	IN2	Digital input 2
4	IN4	Digital input 4
5	IN6	Digital input 6
6	OUT0	Digital output 0
7	OUT2	Digital output 2
8	OUT4	Digital output 4
9	OUT6	Digital output 6
10	BRAKE_X(0)	Digital motor brake output for X(0) axis
11	BRAKE_A(2)	Digital motor brake output for A(2) axis
12	X(0)_MARK1+	Fast non-inverted MARK1 input for axis 0.
13	X(0)_MARK2+	Fast non-inverted MARK2 input for axis 0.
14	Y(1)_MARK1+	Fast non-inverted MARK1 input for axis 1.
15	Y(1)_MARK2+	Fast non-inverted MARK2 input for axis 1.
16	(0)_PEG_PULSE+	Fast non-inverted PEG PULSE output.
17	(1)_PEG_PULSE+	Fast non-inverted PEG PULSE output.
18	DGND	Digital Ground
19	AOUT1	Analog output 1
20	V_RTN_IO	Digital I/O supply return
21	IN1	Digital input 1
22	IN3	Digital input 3

Pin	Name	Description
23	IN5	Digital input 5
24	IN7	Digital input 7
25	OUT1	Digital output 1
26	OUT3	Digital output 3
27	OUT5	Digital output 5
28	OUT7	Digital output 7
29	BRAKE_Y(1)	Digital motor brake output for axis 1
30	BRAKE_B(3)	Digital motor brake output for axis 3
31	X(0)_MARK1-	Fast inverted MARK1 input for axis 0
32	X(0)_MARK2-	Fast inverted MARK2 input for axis 0
33	Y(1)_MARK1-	Fast inverted MARK1 input for axis 1
34	Y(1)_MARK2-	Fast inverted MARK2 input for axis 1
35	(0)_PEG_PULSE-	Fast inverted PEG PULSE output
36	(1)_PEG_PULSE-	Fast inverted PEG PULSE output
37	AOUT0	Analog output 0
	Connector metal case (SHIELD)	Cable shield connection

14.5 J10 – Stepper Drive Control Connector

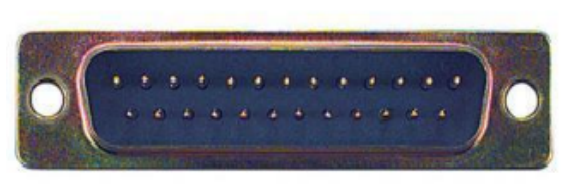

Figure 14-5. J10 Mating Connector



This connector can only be used in conjunction with P/D.

Label: Stepper Drives Control (J10)

Connector Type: DB37 female

Mating Type: DB37 male

Table 14-5. J10 Connector Pinout

J10 Connector Pinout

Pin	Name	Description
1	PULSE_4+	Pulse non-inverted command for axis 4 step motor driver
2	PULSE_5+	Pulse non-inverted command for axis 5 step motor driver
3	PULSE_6+	Pulse non-inverted command for axis 6 step motor driver
4	PULSE_7+	Pulse non-inverted command for axis 7 step motor driver
5	DIR_4+	Direction non-inverted command for axis 4 step motor driver
6	DIR_5+	Direction non-inverted command for axis 5 step motor driver
7	DIR_6+	Direction non-inverted command for axis 6 step motor driver
8	DIR_7+	Direction non-inverted command for axis 7 step motor driver
9	DGND	Digital Ground
10	ENA_4+	Drive enable sink output for axis 4 step motor driver
11	ENA_5+	Drive enable sink output for axis 5 step motor driver
12	ENA_6+	Drive enable sink output for axis 6 step motor driver
13	ENA_7+	Drive enable sink output for axis 7 step motor driver
14	FLT_4+	Drive fault source input for axis 4 step motor driver
15	FLT_5+	Drive fault source input for axis 5 step motor driver

Pin	Name	Description
16	FLT_6+	Drive fault source input for axis 6 step motor driver
17	FLT_7+	Drive fault source input for axis 7 step motor driver
18	V_SUP_I0	Digital I/O supply 5/24Vdc
19	SHIELD	Cable shield connection
20	PULSE_4-	Pulse inverted command for axis 4 step motor driver
21	PULSE_5-	Pulse inverted command for axis 5 step motor driver
22	PULSE_6-	Pulse inverted command for axis 6 step motor driver
23	PULSE_7-	Pulse inverted command for axis 7 step motor driver
24	DIR_4-	Direction inverted command for axis 4 step motor driver
25	DIR_5-	Direction inverted command for axis 5 step motor driver
26	DIR_6-	Direction inverted command for axis 6 step motor driver
27	DIR_7-	Direction inverted command for axis 7 step motor driver
28	DGND	Digital Ground
29	ENA_4-	Drive enable source output for axis 4 step motor driver
30	ENA_5-	Drive enable source output for axis 5 step motor driver
31	ENA_6-	Drive enable source output for axis 6 step motor driver
32	ENA_7-	Drive enable source output for axis 7 step motor driver

Pin	Name	Description
33	FLT_4-	Drive fault sink input for axis 4 step motor driver
34	FLT_5-	Drive fault sink input for axis 5 step motor driver
35	FLT_6-	Drive fault sink input for axis 6 step motor driver
36	FLT_7-	Drive fault sink input for axis 7 step motor driver
37	V_RTN_IO	Digital I/O supply return
	Connector metal case (SHIELD)	Cable shield connection



If it is necessary to supply voltage for the for Enable (ENA) and Fault (FLT) signals, V_SUP_IO is found on pin #18 and V_RTN_IO is found on pin #37.

14.6 J11, J13 & J15 – HALL & Encoder Connectors



Figure 14-6. Hall and Encoder Mating Connector

Label: X(0) Enc. + Hall (J11)

A(2) Enc. + Hall (J13)

Y(1) Enc. + Hall (J15)

Connector Type: DB15 male

Mating Type: DB15 female



The dollar sign (\$) in the table refers to the axis designations which can be 0, 1 or 2 depending on the connector.

Table 14-6. J11, J13 & J15 Connectors Pinout

Pin	Name	Description
1	5U	5.1 V user supply to the \$ Encoder and HALL
2	\$_CHA+	\$ Encoder A non-inverted input /Abs.encoder Data+
3	\$_CHA-	\$ Encoder A inverted input /Abs.encoder Data-
4	\$_CHB+	\$ Encoder B non-inverted input/Abs.encoder Clock+
5	\$_CHB-	\$ Encoder B inverted input /Abs.encoder Clock-
6	DGND	Digital Ground
7	\$_HA	\$ Motor HALL A
8	\$_HB	\$ Motor HALL B
9	\$_CHI+	\$ Encoder Index non- inverted input
10	\$_CHI-	\$ Encoder Index inverted input
11	\$_MTMP_RTN	A return for \$ Motor temperature sensor. (Internally connected to DGND)
12	SHIELD	Cable shield connection
13	5U	5 V user supply to the \$ Encoder and HALL
14	\$_HC	\$ Motor HALL C
15	\$_MTMP	\$ Motor temperature sensor input. A normally closed sensor contact must be connected between pin 15 and pin 11. If no sensor is used, pin 15 must be shorted to pin 11 for proper operation.
	Connector metal case (SHIELD)	Cable shield connection

14.7 J12, J14 & J16 – SIN-COS Encoder Connector



Figure 14-7. SIN-COS Encoder Mating Connector

Label: X(0) Sin-Cos Enc. (J12)

A(2) Sin-Cos Enc. (J14)

Y(1) Sin-Cos Enc. (J16)

Connector Type: DB15 female

Mating Type: DB15 male



The dollar sign (\$) in the table refers to the axis designations which can be 0, 1 or 2 depending on the connector.

Table 14-7. J12, J14 & J16 Pinout

Pin	Name	Description
1	5F	5.1V field supply to the \$ SIN-COS Encoder
2	\$\$SIN+	\$ Encoder SIN non-inverted input
3	\$\$COS+	\$ Encoder COS non-inverted input
4	\$\$INDEX+	\$ SIN-COS Encoder Index non-inverted input
5	AIN#+	Analog non-inverted input # (0 in J12, 2 in J14, 4 in J16)
6	AIN@+	Analog non-inverted input @ (1 in J12, 3 in J14, 5 in J16)
7	X_MTMP	X Motor temperature sensor input. A normally closed sensor contact must be connected between pin 15 and pin 7. If no sensor is used, pin 15 must be shorted to pin 7 for proper operation.
8	SHIELD	Cable shield connection
9	AGND	Analog Ground for 5F field supply

Pin	Name	Description
10	\$SIN-	\$ Encoder SIN inverted input
11	\$COS-	\$ Encoder COSinverted input
12	\$INDEX-	\$ SIN-COS Encoder Index inverted input
13	AIN#-	Analog non-inverted input # (0 in J12, 2 in J14, 4 in J16)
14	AIN@-	Analog non-inverted input @ (1 in J12, 3 in J14, 5 in J16)
15	DGND	Digital Ground (return for X Motor temperature sensor)
	Connector metal case (SHIELD)	Cable shield connection

14.8 J17 – Control & Brake Supply Connector



Figure 14-8. J17 Mating Connector

Label: Control & Brake Supply (J17)

Connector Type: PHOENIX 5 pin, MC-1.5/5 GF 3.81 BK

Mating Type: PHOENIX 5 pin, MC 1,5/ 5-STF-3,81 BK

Table 14-8. J17 Connectors Pinout

Pin	Name	Description
1	PE	Electrical Ground
2	BRK_RTN	Brake supply return
3	BRK_SUP	5/24Vdc brake supply
4	24V_RTN	24Vdc control supply return
5	24Vdc	24Vdc control supply

14.9 J18 – Drive Supply Connector



Figure 14-9. J18 Mating Connector

Label: Drive Supply (J18)

Connector Type: Weidmuller SV 7.62HP/04/90F 3.5SN BK BX

Mating Type: BVZ 7.62HP/04/180F SN BK

Table 14-9. J18 Connector Pinout

Pin	Name	Description
1	L1	Phase "L1" for 115/230Vac input (phase input for single phase supply) When using a DC supply this pin should be connected to the "+" terminal
2	L2	Phase "L2" for 115/230Vac input (neutral input for single phase supply) When using a DC supply this pin should be connected to the "-" terminal
3	L3	Phase "L3" for 230Vac input When using a DC supply this pin should not be connected.
4	PE	Electrical Ground

14.10 J19 – Regeneration Connector



Figure 14-10. Regeneration mating connector

Actual connector has 3 pins, image is for reference

Label: Regeneration (J19)

Mating Type: BVZ 7.62HP/03/180F BK WEIDMULLER

Table 14-10. Connector Pinout

Pin	Name	Description
1	REG1	Internal regeneration Resistor
2	REG2	Vbus+ for external shunt application
3	REG3	Common regeneration pin

14.11 J20, J21 & J22 Motor Outputs Connector

Label: X(0) Motor Output (J20)

A(2) Motor Output (J21)

Y(1) Motor Output (J22)

Connector Type: PHOENIX 6-pin, PC 4/6-G-7.62 BK

Mating Type: PHOENIX PC 4/ 6-STF-7,62 BK



The dollar sign (\$) in the table refers to the axis designations which can be 0, 1 or 2 depending on the connector.

Table 14-11. J20, J21 & J22 Connector Pinout

Pin	Name	Description
1	\$R	\$ Motor phase "R"
2	\$S	\$ Motor phase "S"
3	\$T	\$ Motor phase "T"
4	PE	Electrical Ground
5	\$BRK+	5/24 Vdc 1 A brake output
6	\$BRK-	Brake output return

14.12 J26 – PEG Connector



Figure 14-11. J26 Mating Connector

Label: PEG & Analog Inputs (J26)

Connector Type: DB25 female

Mating Type: DB25 male

Table 14-12. Connector Pinout

Pin	Name	Description
1	(0)_PEG_PULSE+	Fast non-inverted PEG PULSE.
2	(0)_STATE0+	Fast non-inverted PEG STATE

Pin	Name	Description
3	(0)_STATE1+	Fast non-inverted PEG STATE
4	(0)_STATE2+	Fast non-inverted PEG STATE
5	(0)_STATE3+	Fast non-inverted PEG STATE
6	(1)_PEG_PULSE+	Fast non-inverted PEG PULSE output
7	(1)_STATE0+	Fast non-inverted PEG STATE
8	(1)_STATE1+	Fast non-inverted PEG STATE
9	(1)_STATE2+	Fast non-inverted PEG STATE
10	(1)_STATE3+	Fast non-inverted PEG STATE
11	GND	Digital Ground.
12	AGND	Analog Ground
13	AGND	Analog Ground
14	(0)_PEG_PULSE-	Fast inverted PEG PULSE output.
15	(0)_STATE0-	Fast inverted PEG STATE
16	(0)_STATE1-	Fast inverted PEG STATE
17	(0)_STATE2-	Fast inverted PEG STATE
18	(0)_STATE3-	Fast inverted PEG STATE
19	(1)_PEG_PULSE-	Fast inverted PEG PULSE output
20	(1)_STATE0-	Fast inverted PEG STATE
21	(1)_STATE1-	Fast inverted PEG STATE
22	(1)_STATE2-	Fast inverted PEG STATE
23	(1)_STATE3-	Fast inverted PEG STATE
24	AIN6	Analog input 6 (single-ended)
25	AIN7	Analog input 7 (single-ended)

14.13 J29 Encoder Connector

Label: Encoder (J29)

Connector Type: DB15 male

Mating Type: DB15 female

Table 14-13. J29 Connector Pinout

Pin	Name	Description
1	5U	5.1V user supply to the Encoder and HALL
2	B(3)_CHA+	B(3)_ Encoder A non-inverted input
3	B(3)_CHA-	B(3)_ Encoder A inverted input
4	B(3)_CHB+	B(3)_ Encoder B non-inverted input
5	B(3)_CHB-	B(3)_ Encoder B inverted input
6	DGND	Digital Ground
7	NC	Not Connected
8	NC	Not Connected
9	B(3)_CHI+	Encoder Index non-inverted input
10	B(3)_CHI-	Encoder Index inverted input
11	DGND	Digital Ground
12	SHIELD	Cable shield connection
13	5U	5.1V user supply to the B Encoder and HALL, 200mA max
14	NC	Not Connected
15	B_MTMP	B Motor temperature sensor input. A normally closed sensor contact must be connected between pin 15 and pin 11. If no sensor is used, pin 15 must be shorted to pin 11 for proper operation.
	Connector metal case (SHIELD)	Cable shield connection

14.14 STO Connector



Figure 14-12. STO Connector

Label: J30

Mating Type:

JST 5 PIN 2mm female

PAP-05V-S

Pin type: SPHD-001T-P0.5

See [STO Breakout Cable](#) for optional breakout cable.

Table 14-14. STO Connector Pinout

Pin	Name	Description
1	ST01-	STO input 1 inverted input
2	ST01+	STO input 1 non inverted input
3	NC	not connected
4	ST02+	STO input 2 non inverted input
5	ST02-	STO input 2 inverted input

Smarter



Motion

www.acsmotioncontrol.com
2010 Summer 1, 2011

5 HaTnufa St.
Yokne'am Illit 2066717
Israel
Tel: (+972) (4) 654 6440 Fax: (+972) (4) 654 6443

Contact us: sales@acsmotioncontrol.com | www.acsmotioncontrol.com

