

IBX-504C Wall-mounted industrial case

IBX-504C

IBX-504C Wall-mounted industrial case



Features:

- Wall-mounted chassis supports Micro ATX industrial motherboard
- Design of anti vibration disk rack
- Can support one 2.5 inch hard disk and one 3.5 inch hard disk
- The Flex Standard 1U power supply
- Easy maintenance of the structure mode
- 10cm Ball bearing fan

Specifications

Component name	Specifications
Drive space	1×3.5"HDD,1×2.5"HDD/SSD
System fan	1×100mm radiator fan
Extended slot	4× full-high PCI / PCIE expansion slots
Suitable for motherboard	Micro ATX External USB interface
USB interface	2×External USB interface
System control	1*Power、1*Power led、1*HDD led
Power	The Flex Standard 1U power supply
Working temperature	- 20°~60°
Size (W×H×D)	300mm×146.3mm×285mm
Package size	420mm×264mm×433mm
Weight	4KG



- ①.Power position ②.Power SW
③.External USB interface

Product size

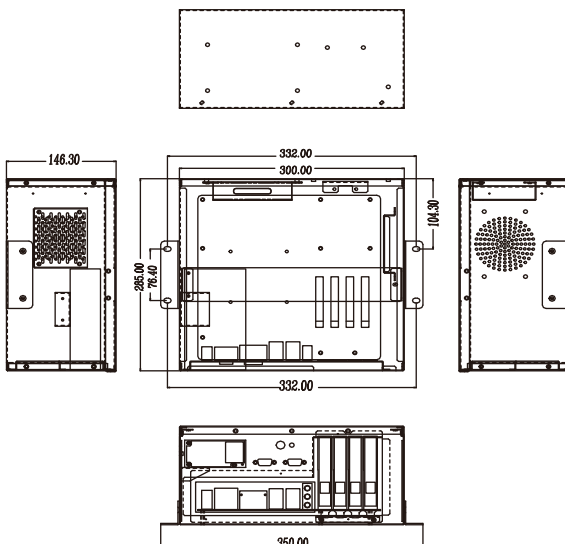

- ①.Fan position